

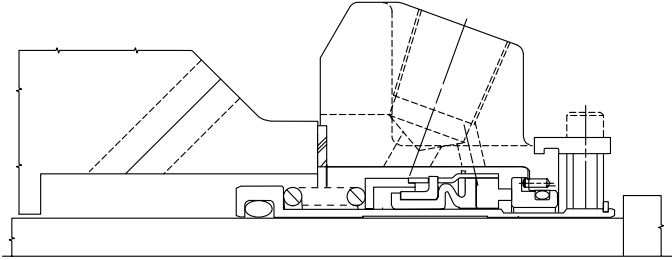

**John Crane**  
**Type 5611 and 5611Q**  
**Elastomer Bellows**  
**Cartridge Seal**  
**Assembly and**  
**Installation Instructions**



## Foreword

These instructions are provided to familiarize the user with the seal and its designated use. The instructions must be read and applied whenever work is done on the seal, and must be kept available for future reference.

**ATTENTION** These instructions are for the installation and operation of a seal as used in rotating equipment and will help to avoid danger and increase reliability. The information required may change with other types of equipment or installation arrangements. These instructions must be read in conjunction with the instruction manuals for both the pump and any ancillary equipment.

If the seal is to be used for an application other than that originally intended or outside the recommended performance limits, John Crane must be contacted before its installation and use.

Any warranty may be affected by improper handling, installation, or use of this seal. Contact the Company for information as to exclusive product warranty and limitations of liability.

If questions or problems arise, contact your local John Crane Sales/Service Engineer or the original equipment manufacturer, as appropriate.

**ATTENTION** John Crane mechanical seals are precision products and must be handled appropriately. Take particular care to avoid damage to lapped sealing faces and to flexible sealing rings. Do not excessively compress the seal before or during installation.

## Safety Instructions

1. The following designations are used in the installation instructions to highlight instructions of particular importance.

**NOTE:** Refers to special information on how to install or operate the seal most efficiently.

**ATTENTION** Refers to special information or instructions directed towards the prevention of damage to the seal or its surroundings.



Refers to mandatory instructions designed to prevent personal injury or extensive damage to the seal or its surroundings.

2. Installation, removal and maintenance of the seal must be carried out only by qualified personnel who have read and understood these installation instructions.
3. The seal is designed exclusively for sealing rotating shafts. The manufacturer cannot be held liable for use of the seal for purposes other than this.

4. The seal must only be used in technically perfect condition, and must be operated within the recommended performance limits in accordance with its designated use set out in these installation instructions.
5. If the pumped fluid is hazardous or toxic, appropriate precautions must be taken to ensure that any seal leakage is adequately contained. Further information on sealing hazardous or toxic fluids should be obtained from John Crane prior to seal installation.
6. Fluorocarbon components should never be burned or incinerated as the fumes and residues are highly toxic. If fluorocarbons are accidentally heated above 400°C/750°F, they can decompose. Therefore, protective gloves should be worn as hydrofluoric acid may be present.
7. PTFE components should never be burned or incinerated as the fumes are highly toxic.

## Before Starting the Equipment

1. Check the pump at the coupling for proper alignment of the driver or motor.
2. Ensure that the gland plate nuts/bolts are securely tightened according to the pump manual instructions, and that all screws are securely fastened.
3. Complete the assembly of the pump, and turn the shaft (by hand if possible) to ensure free rotation.
4. Consult all available equipment operating instructions to check for correctness of all piping and connections, particularly regarding seal recirculation/flush, heating or cooling requirements, and services external to the seal.

**ATTENTION** This mechanical seal is designed to operate in a liquid so the heat energy it creates is adequately removed. Therefore, the following check should be carried out not only after seal installation, but also after any period of equipment inactivity.

5. Check that the seal chamber fluid lines are open and free of any obstruction, and ensure that the seal chamber is properly vented and filled with liquid - refer to the pump instruction manual.

**ATTENTION** Dry-running—often indicated by a squealing noise from the seal area—will cause overheating and scoring or other damage to the sealing surfaces, resulting in excessive leakage or a much shortened seal life.



**Before start-up, ensure that all personnel and assembly equipment have been moved to a safe distance so there is no contact with rotating parts on the pump, seal, coupling, or motor.**

**WARNING:** Seal installation should be handled only by qualified personnel. If questions arise, contact the local John Crane Sales/Service Engineer. Improper use and/or installation of this product could result in injury to the person and/or harmful emissions to the environment, and may affect any warranty on the product. Please contact the company for information as to exclusive product warranty and limitations of liability.

## General Instructions

1. Study the engineering layout drawing to confirm the proper seal arrangements for the pump being used. The following instructions describe the standard configurations.
2. To assure satisfactory operation, handle seal with care. Take particular caution to see that the lapped sealing faces are not scratched or marred.

## Typical Type 5611/5611Q Standard Seal Arrangement

Part Name		
1 Mating Ring	7 Collar	13 Adapter
2 O-Ring	8 Set Screws	14 Gasket
3 Primary Ring	9 Spacers	15 Drive Band
4 Bellows	10 Cap Screws	16 Retainer
5 Sleeve	11 Gland Plate Assembly	17 Disc
6 O-Ring	12 Spring	18 Snap Ring
		19 Bushing

### Typical Type 5611 Cartridge Arrangement

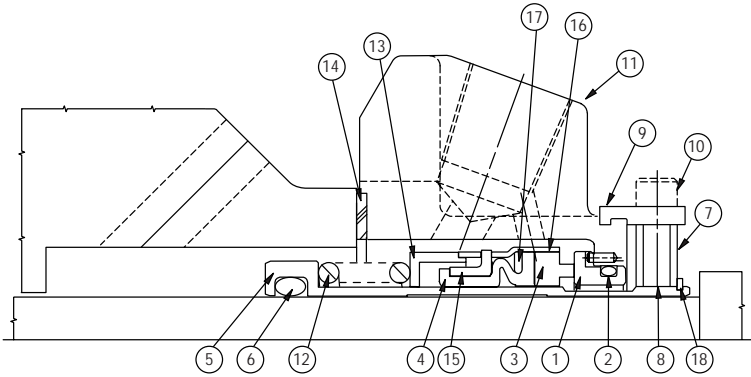

### Typical Type 5611Q Cartridge Arrangement

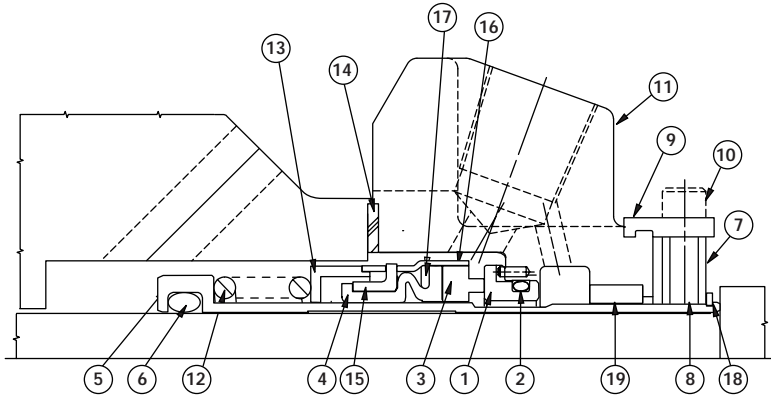

## Preparing the Equipment

1. Check seal chamber dimensions and finishes.

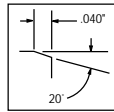
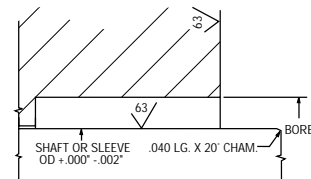

2. Measure axial end play: Sizes up to 3.000": .003"/.08mm F.I.M.  
Over 3.000": .005"/.13mm F.I.M.

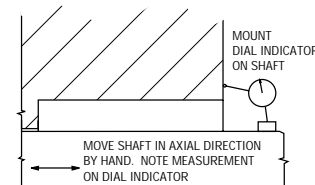

**NOTE:** If measured dimensions exceed those values given, correct the equipment to meet specifications prior to seal installation.

3. Determine squareness of seal chamber face to shaft.

Sizes up to 3.000": .005"/.13mm F.I.M.  
Over 3.000": .007"/.18mm F.I.M.

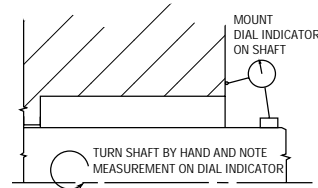

4. Measure shaft runout: Sizes up to 3.000": .002"/.05mm F.I.M.  
Over 3.000": .003"/.08mm F.I.M.

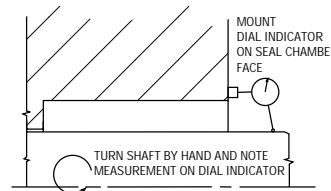

## Type 5611 and 5611Q Elastomer Bellows Cartridge Seal Assembly

Assemble the Type 5611 or 5611Q as follows, referring to the applicable engineering layout drawing.

**NOTE:** Elastomeric O-rings can be damaged or destroyed if care is not taken. Prior to assembly of O-ring into groove, make sure groove is clean and free of foreign materials. Lubricate both groove and O-ring prior to installation with light lube oil (SAE #10 or #20) or silicone grease (such as Dow Corning compound #4.) For ethylene propylene elastomers, do not lubricate with petroleum products.

1. Place gland plate on table with gasket side facing up. Mark appropriate M# on the flat surface area between the gasket and the large OD chamfer.

2. Install lubricated O-ring into OD groove of mating ring.
3. Gently press the mating ring with lapped face up into the gland bore, aligning notches of mating ring with pins of gland plate. (Note: It may be helpful to mark the pin location on the counter-bore of gland plate with a felt tipped pen before installing mating ring.) Turn gland plate over and confirm that mating ring is flush with end of gland plate.
4. Install set screws in collar.
5. Loosely attach the spacers to the collar with cap screws.
6. Set the gland plate assembly gasket side down on table. Install collar on gland plate assembly and engage spacers into groove, aligning spacers with pipe taps of gland plate. Uniformly finger tighten the cap screws. This sets the radial spacing of the cartridge.
7. Install disc into the retainer, rotating the disc slightly to secure it in place.

## Type 5611 and 5611Q Elastomer Bellows Cartridge Seal Assembly (cont.)

8. Install drive band, ears first, into the notches in the back of the retainer. The leg of the drive band without ears should be facing away from the retainer.
9. Turn the bellows inside-out and place it with the retainer/drive band/disc assembly.
10. Turn the bellows right-side-out, folding the bellows into the lip of the drive band and completely around the disc. Gently pull on the bellows to ensure it is properly seated. The disc should not be visible once this step is completed.
11. Install the primary ring, lapped face up, into the retainer assembly so the un-lapped face rests against the front flange of the bellows.
12. Lightly lubricate the ID of the bellows. Lightly lubricate the OD of the entire sleeve for best results.
13. With the sleeve standing on its base, first install the spring, then the spring adapter. The flat side of the spring adapter should rest on top of the spring. The adapter should not enclose the spring.
14. Carefully slide the seal head assembly onto the sleeve, ensuring the tail of the bellows remains flat. Should the bellows roll under, remove the seal head from the sleeve and restart this step, gently turning the seal head. Once the seal head assembly is correctly positioned, gently slide it back and forth once to ensure its mobility.
15. Clean faces of primary and mating rings with denatured alcohol and a lint-free cloth.
16. With the entire assembly still standing on the sleeve base, carefully lower the gland plate assembly over the sleeve assembly until the seal faces touch. Carefully rotate the faces against each other one or two turns.
17. Align set screws in collar with through holes in end of sleeve.
18. Install snap ring over the end of sleeve. This sets the axial spacing of the cartridge. **Do not overcompress gland plate or this may damage the seal.**
19. Tighten set screws until they start to enter the sleeve ID.
20. Uniformly tighten cap screws on spacers.
21. To allow for longest possible face wear, check to ensure ears of drive band still rest in bottom of retainer notches.
22. Install gasket and sleeve o-ring. Apply a small amount of "vistic" to gasket to hold it in place.
23. Pressure test according to John Crane standard QA-5-0568.
24. Plug gland pipe taps with plastic plugs.

### Type 5611 Installation Dimensions

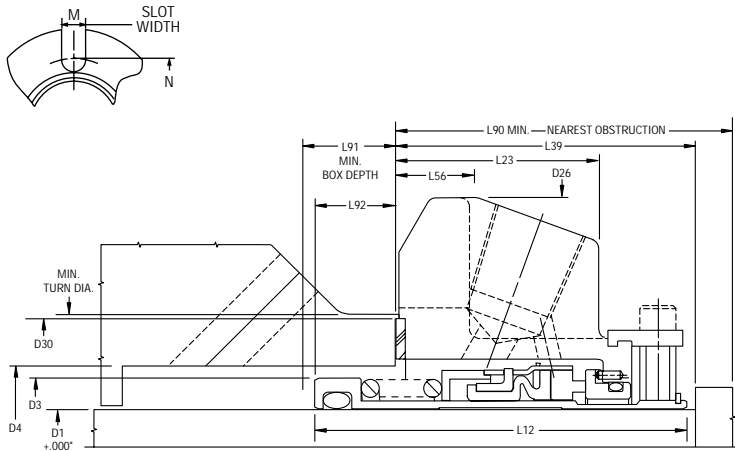

### Type 5611Q Installation Dimensions

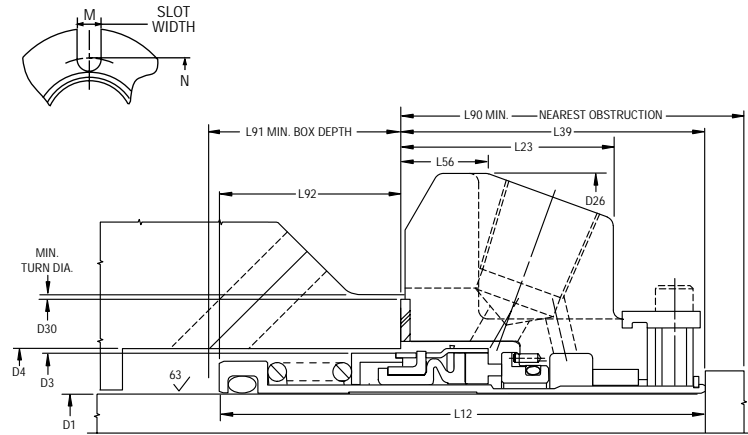

### Type 5611 Cartridge Dimensional Data (inches)

Seal Size	D4		D26	L12	L23	L39	L56	L90	L91	L92	M	N	
	D1	D3											
1.000	1.375	1.500	1.889	4.000	2.739	1.353	1.954	0.531	2.000	0.910	0.785	0.525	2.805
1.125	1.500	1.625	2.015	4.125	2.595	1.446	2.062	0.531	2.125	0.685	0.533	0.525	2.933
1.250	1.687	1.812	2.294	4.250	2.718	1.446	2.062	0.531	2.125	0.781	0.656	0.525	3.213
1.375	1.812	1.937	2.421	4.375	2.625	1.446	2.062	0.531	2.125	0.688	0.563	0.525	3.338
1.500	2.000	2.125	2.680	4.875	2.960	1.487	2.125	0.593	2.187	0.960	0.835	0.525	3.599
1.625	2.125	2.250	2.812	5.000	3.022	1.487	2.125	0.593	2.187	1.022	0.897	0.562	3.766
1.750	2.250	2.375	2.918	5.250	3.038	1.487	2.125	0.593	2.187	1.038	0.913	0.562	3.875
1.875	2.375	2.500	2.918	5.250	3.038	1.487	2.125	0.593	2.187	1.038	0.913	0.562	3.875
2.000	2.687	2.750	3.015	5.500	3.454	1.601	2.312	1.063	2.375	1.266	1.141	0.562	4.000
2.125	2.812	2.875	3.360	5.859	3.454	1.601	2.312	0.593	2.375	1.266	1.141	0.687	4.469
2.250	2.750	2.875	3.485	6.500	3.579	1.601	2.312	0.593	2.375	1.391	1.266	0.687	4.566
2.375	3.062	3.125	3.610	6.500	3.468	1.717	2.466	0.625	2.528	1.127	1.002	0.687	4.719
2.500	3.250	3.375	3.891	6.750	3.892	1.717	2.563	0.625	2.625	1.391	1.266	0.687	5.000
2.625	3.500	3.625	4.062	6.750	3.978	1.625	2.500	0.625	2.562	1.603	1.478	0.687	5.170
2.750	3.500	3.625	4.062	6.750	3.978	1.625	2.500	0.625	2.562	1.603	1.478	0.687	5.170
2.875	3.625	3.695	4.186	7.000	3.978	1.725	2.500	0.625	2.562	1.603	1.478	0.687	5.312
3.000	3.937	4.000	4.469	7.750	4.172	1.787	2.562	0.685	2.625	1.735	1.610	0.812	5.720
3.125	4.062	4.125	4.600	7.875	4.187	1.593	2.562	-	2.687	1.750	1.625	0.812	5.845
3.250	4.062	4.125	4.600	7.437	4.187	1.593	2.510	-	2.635	1.802	1.677	0.812	5.845
3.375	4.312	4.375	4.850	8.125	4.375	1.593	2.562	-	2.687	1.938	1.813	0.812	6.095
3.500	4.437	4.500	4.975	8.250	4.344	1.593	2.562	-	2.687	1.907	1.782	0.812	6.220
3.625	4.562	4.625	5.100	8.375	4.625	1.593	2.562	-	2.687	2.188	2.063	0.687	6.250
3.750	4.632	4.724	5.199	8.750	4.437	1.593	2.562	-	2.687	2.000	1.875	0.687	6.770
3.875	4.812	4.905	5.375	8.750	4.500	1.593	2.562	-	2.687	2.063	1.938	0.812	6.636
4.000	4.937	5.031	5.500	9.000	4.812	1.593	2.562	-	2.687	2.375	2.250	0.812	6.761
5.000	6.500	6.593	7.260	12.000	5.750	1.749	3.043	-	3.168	2.832	2.707	0.812	10.000

### Type 5611Q Cartridge Dimensional Data (inches)

Seal Size	D4		D26	L12	L23	L39	L56	L90	L91	L92	M	N	
	D1	D3											
1.000	1.562	1.625	1.889	4.000	3.327	1.353	1.954	0.531	2.000	1.498	1.373	0.525	2.805
1.125	1.687	1.750	2.015	4.125	3.183	1.446	2.062	0.531	2.125	1.246	1.121	0.525	2.933
1.250	1.812	1.875	2.294	4.250	3.390	1.446	2.062	0.531	2.125	1.453	1.328	0.525	3.213
1.375	1.936	2.000	2.421	4.375	3.290	1.446	2.062	0.531	2.125	1.353	1.228	0.525	3.338
1.500	2.156	2.218	2.680	4.875	3.548	1.487	2.125	0.593	2.187	1.548	1.423	0.525	3.599
1.625	2.281	2.343	2.812	5.000	3.610	1.487	2.125	0.593	2.187	1.610	1.485	0.562	3.766
1.750	2.406	2.480	2.918	5.250	3.626	1.487	2.125	0.593	2.187	1.626	1.501	0.562	3.875
1.875	2.531	2.625	2.918	5.250	3.626	1.487	2.125	0.593	2.187	1.626	1.501	0.562	3.875
2.000	2.687	2.750	3.015	5.500	4.042	1.601	2.312	1.063	2.375	1.854	1.729	0.562	4.000
2.125	2.812	2.875	3.360	5.859	4.042	1.601	2.312	0.593	2.375	1.854	1.729	0.687	4.469
2.250	2.937	3.000	3.485	6.500	4.167	1.601	2.312	0.593	2.375	1.979	1.854	0.687	4.566
2.375	3.062	3.125	3.610	6.500	4.062	1.717	2.466	0.625	2.528	1.783	1.596	0.687	4.719
2.500	3.250	3.375	3.891	6.750	4.325	1.717	2.563	0.625	2.625	1.887	1.762	0.687	5.000
2.625	3.500	3.625	4.062	6.750	4.566	1.625	2.500	0.625	2.562	2.191	2.066	0.687	5.170
2.750	3.500	3.625	4.062	6.750	4.566	1.625	2.500	0.625	2.562	2.191	2.066	0.687	5.170
2.875	3.625	3.695	4.186	7.000	4.578	1.725	2.500	0.625	2.562	2.203	2.078	0.687	5.312
3.000	3.937	4.000	4.469	7.750	4.750	1.787	2.562	0.685	2.625	2.313	2.188	0.812	5.720
3.125	4.062	4.125	4.600	7.875	4.781	1.593	2.562	-	2.687	2.344	2.219	0.812	5.845
3.250	4.062	4.125	4.600	7.437	4.781	1.593	2.510	-	2.635	2.333	2.208	0.812	5.845
3.375	4.312	4.375	4.850	8.125	4.969	1.593	2.562	-	2.687	2.532	2.407	0.812	6.095
3.500	4.437	4.500	4.975	8.250	4.969	1.593	2.562	-	2.687	2.532	2.407	0.812	6.220
3.625	4.562	4.625	5.100	8.375	5.218	1.593	2.562	-	2.687	2.781	2.656	0.687	6.250
3.750	4.687	4.781	5.199	8.750	5.031	1.593	2.562	-	2.687	2.594	2.469	0.687	6.770
3.875	4.875	4.968	5.375	8.750	5.093	1.593	2.562	-	2.687	2.656	2.531	0.812	6.636
4.000	5.021	5.114	5.500	9.000	5.406	1.593	2.562	-	2.687	2.969	2.844	0.812	6.761
5.000	6.500	6.593	7.260	12.000	6.406	1.749	3.043	-	3.168	3.488	3.363	0.812	10.000

## Type 5611 Oversize Bore Cartridge Dimensional Data (inches)

Seal Size/D1	D3	D4		D26	L12	L23	L39	L56	L90	L91	L92	M	N	Min. Turn Dia.
		Min.	Max.											
1.375	1.812	2.875	3.023	5.375	2.625	1.446	2.062	0.625	2.125	0.688	0.563	0.562	4.062	3.268
1.750	2.250	3.500	3.925	6.500	3.038	1.487	2.125	0.656	2.187	1.038	0.913	0.687	5.093	3.885
1.875	2.375	3.625	3.734	6.500	3.038	1.316	1.954	0.485	2.017	1.209	1.084	0.687	5.093	*
2.125	2.687	3.875	4.250	7.156	3.454	1.570	2.282	0.749	2.407	0.297	1.172	0.687	5.687	4.264
2.500	3.250	4.750	4.875	8.000	3.829	1.697	2.407	0.656	2.532	1.547	1.422	0.687	6.062	5.139
2.625	3.437	4.625	4.740	8.000	3.978	1.617	2.329	0.578	2.454	1.774	1.649	0.687	6.062	**
2.750	3.437	4.750	4.875	8.000	3.978	1.697	2.407	0.656	2.532	1.696	1.571	0.687	6.062	5.139

\* Seal cartridge is OD registered on the Turn Dia. of 4.125".

\*\* Seal cartridge is OD registered on the Turn Dia. of 5.125".

## Type 5611Q Oversize Bore Cartridge Dimensional Data (inches)

Seal Size/D1	D3	D4		D26	L12	L23	L39	L56	L90	L91	L92	M	N	Min. Turn Dia.
		Min.	Max.											
1.375	1.937	2.875	3.023	5.375	3.290	1.446	2.062	0.625	2.125	1.353	1.228	0.562	4.062	3.268
1.750	2.406	3.500	3.925	6.500	3.626	1.487	2.125	0.656	2.187	1.626	1.501	0.687	5.093	3.885
1.875	2.530	3.625	3.734	6.500	3.626	1.316	1.954	0.485	2.017	1.797	1.672	0.687	5.093	*
2.125	2.812	3.875	4.250	7.156	4.042	1.570	2.282	0.749	2.407	1.885	1.760	0.687	5.687	4.264
2.500	3.250	4.750	4.875	8.000	4.325	1.697	2.407	0.656	2.532	2.043	1.918	0.687	6.062	5.139
2.625	3.625	4.625	4.740	8.000	4.566	1.617	2.329	0.578	2.454	2.362	2.237	0.687	6.062	**
2.750	3.500	4.750	4.875	8.000	4.566	1.697	2.407	0.656	2.532	2.284	2.159	0.687	6.062	5.139

\* Seal cartridge is OD registered on the Turn Dia. of 4.125".

\*\* Seal cartridge is OD registered on the Turn Dia. of 5.125".

## Installing the Seal

1. Before starting the installation, read the following instructions carefully.
2. Remove the seal from its packaging, inspect for any damage, and wipe clean.
3. The equipment should be clean and meet the specifications noted in the "Preparing the Equipment" section. Lubricate sleeve O-ring with lubricant recommended in chart below. Lubricate shaft sparingly. Lubricate gland plate bolts/nuts as required.

ELASTOMER	LUBRICANT
Fluoroelastomer (i.e. Viton™)	Vegetable Oil, Animal Oil, Mineral-Hydrocarbon Oils, Soap Solution, Parker 'Super-O-Lube', Silicone Grease
Ethylene Propylene	Vegetable Oil, Polywater™, Soap Solution, Glycerine, Propylene Glycol, Silicone Grease
Perfluoroelastomer (i.e. Kalrez™)	Vegetable Oil, Animal Oil, Mineral-Hydrocarbon Oils
<p><b>NOTE:</b> Always use a lubricant that is compatible with your machinery and product. Use lubricant sparingly, only enough to install seal with ease.</p> <p>Viton and Kalrez are registered trademarks of DuPont. Polywater is a registered trademark of American Polyware Co.</p>	

4. Make sure that gland plate gasket (Type 5611) is properly positioned, and that collar set screws do not extend past sleeve ID. Slide complete cartridge seal assembly onto shaft. Position gland plate so pipe connection #1 is at or near top dead center for ANSI pumps. For DIN pumps, position gland plate so slot between pipe connections #3 and #4 is at or near top dead center. Slide cartridge onto studs (if applicable) until gasket is flush against the face of seal chamber. Hand tighten gland plate bolts/nuts.
5. Reassemble pump and make all necessary impeller adjustments.
6. Continue tightening gland plate bolts/nuts in an alternating pattern until secure (1/4 turns, 180° apart), with gland plate (Type 5611) and face of pump seal chamber metal-to-metal. Do not over-stress or distort gland plate.
7. Tighten collar set screws evenly (1/4 turns, 180° apart), securing cartridge seal to shaft.
8. Remove spacers and save.
9. Make appropriate piping connections to seal assembly.

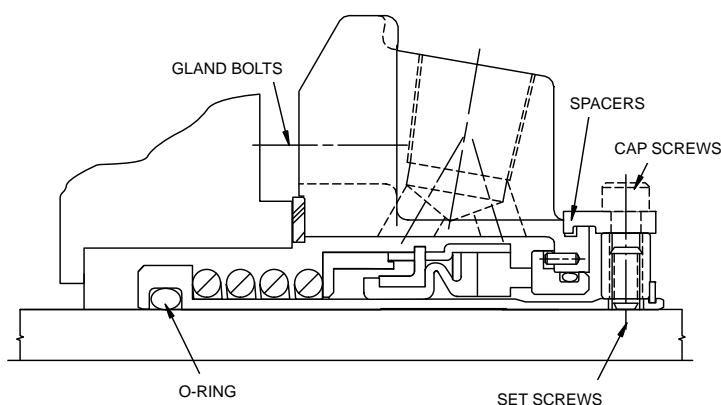

## Type 5611 ANSI/DIN Gland Piping Arrangements

Refer to Piping Schematics included in seal packing

## After the Equipment has Run

1. Ensure that the pump is electrically isolated.



If the equipment has been used on toxic or hazardous fluids, ensure that the equipment is correctly decontaminated and made safe prior to commencing work. Remember fluid is often trapped during draining and may exist outside the seal. The pump instruction manual should be consulted to check for any special precautions.

2. Ensure that the pump is isolated by the appropriate valves. Check that the fluid is drained and pressure is fully released.

## Ordering Information

1. Cartridge Seal size = solid shaft or sleeve OD.
2. Select arrangement.
3. Determine whether standard or enlarged seal chamber configuration is required.
4. Choose seal drawing number from chart below.
5. For other material combinations or size considerations, consult the local John Crane Sales/Service Engineer.

## Materials of Construction

Primary Ring	Carbon Graphite or Resin Impregnated Carbon
Mating Ring	Silicon Carbide
Cartridge Hardware	316 S.S.
Secondary Seal	Fluoroelastomer

## Operating Limits

Pressure:	27 bar g/400 psig
Temperature:	-29°C to +204°C/-20°F to +400°F
Speed:	To 25 m/s/5000 fpm

## Type 5611/5611Q Cartridge Drawing Numbers Standard Bore Layouts

	5611	5611Q
1.000	H-SP-39551	H-SP-39552
1.125	H-SP-37337	H-SP-37345
1.250	H-SP-39562	H-SP-39563
1.375	H-SP-37338	H-SP-37346
1.500	H-SP-39572	H-SP-39573
1.625	H-SP-39582	H-SP-39583
1.750	H-SP-37339	H-SP-37347
1.875	H-SP-37340	H-SP-37348
2.000	H-SP-39592	H-SP-39593
2.125	H-SP-37341	H-SP-37349
2.250	H-SP-39602	H-SP-39603
2.375	H-SP-39612	H-SP-39613
2.500	H-SP-37342	H-SP-37350
2.625	H-SP-37343	H-SP-37351
2.750	H-SP-37344	H-SP-37352
2.875	H-SP-39622	H-SP-39623
3.000	H-SP-39632	H-SP-39633
3.125	H-SP-41628	H-SP-41629
3.250	H-SP-41633	H-SP-41634
3.375	H-SP-41639	H-SP-41640
3.500	H-SP-41644	H-SP-41645
3.625	H-SP-41649	H-SP-41650
3.750	H-SP-41654	H-SP-41655
3.875	H-SP-41957	H-SP-41958
4.000	H-SP-41659	H-SP-41660
5.000	H-SP-42122	H-SP-42123

## Type 5611/5611Q Cartridge Drawing Numbers Oversized Bore Layouts

	5611	5611Q
1.375	H-SP-38061	H-SP-38062
1.750	H-SP-38071	H-SP-38072
1.875	H-SP-38081	H-SP-38082
2.125	H-SP-39038	H-SP-39039
2.500	H-SP-39011	H-SP-39012
2.625	H-SP-38091	H-SP-38092
2.750	H-SP-39021	H-SP-39022

## Maintenance

No maintenance of a seal is possible while installed. Therefore, it is recommended that a spare seal unit and mating ring be held in stock to allow immediate replacement of a removed seal.

It is recommended that used seals are returned to a John Crane Seal Rebuilding Center, as rebuilding to as-new specifications must be carried out by qualified personnel.



It is the responsibility of the equipment user to ensure that any parts being sent to a third party have appropriate safe handling instructions externally attached to the package.

## Quality Assurance

This seal has been assembled in accordance with John Crane Quality Assurance Standards and with proper maintenance and use will give safe and reliable operation to the maximum recommended performance as shown in any relevant approved John Crane publication.



<b>North and Latin America</b>	<b>Europe, Middle East, Africa</b>	<b>Asia Pacific</b>	<b>John Crane Sealol®</b>	<b>John Crane Safematic®</b>	<b>John Crane Flexibox®</b>
Morton Grove, Illinois USA	Slough, UK	Singapore	Cranston, Rhode Island USA	Muurame, Finland	Manchester, UK
Tel: 1-847-967-2400	Tel: 44-1753-224000	Tel: 65-222-9161	Tel: 1-401-463-8700	Tel: 338-14-600-611	Tel: 44-161-8722484
Fax: 1-847-967-3915	Fax: 44-1753-224224	Fax: 65-223-5035	Fax: 1-401-463-6198	Fax: 338-14-600-600	Fax: 44-161-8489812
1-800-SEALING					

If the products featured will be used in a potentially dangerous and/or hazardous process, your John Crane representative should be consulted prior to their selection and use. In the interest of continuous development, John Crane Companies reserve the right to alter designs and specifications without prior notice. It is dangerous to smoke while handling products made from PTFE. Old and new PTFE products must not be incinerated.