



# TYPE 37FS

Fully Split Seal

37FS

- A – Primary Ring
- B – Mating Ring
- C – Compression Ring
- D – Sealing Ring
- E – Gland Plate
- F – Clamp Ring
- G – Drive Ring
- H – Fasteners
- I – Retaining Ring
- J – Cord Segment

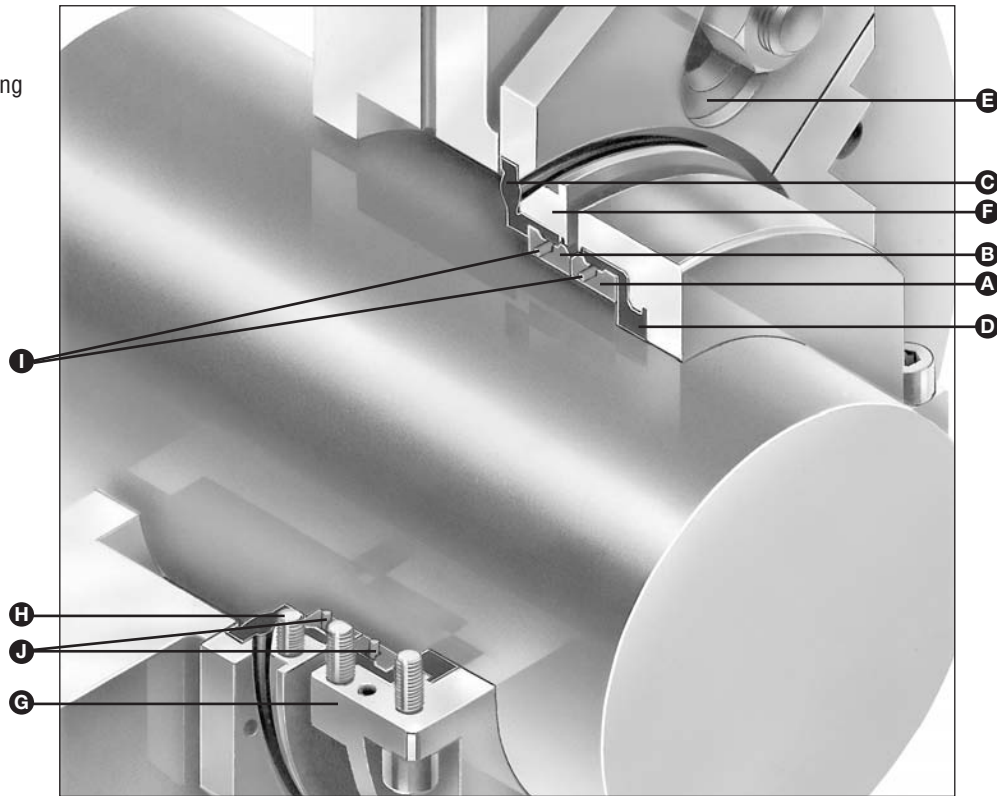

## Product Description

The Type 37FS fully split seals contribute to significantly reduced maintenance on larger, difficult-to-seal equipment. They are recommended for use on heavy duty, packed equipment that previously could not accommodate mechanical seals because of severe shaft runout and vibration, difficulty to disassemble, worn out equipment, and similar problems. Type 37FS seals are outside mounted and can be used on vertical and horizontal applications.

- For use on large, heavy duty rotating shaft equipment such as mixers, agitators, pumps.
- For pulp and paper, power generation, food processing, wastewater treatment, mining and other demanding industries.

## Performance Capabilities

- Temperatures:  
82°C/180°F max.
- Pressures:  
5.5 barg/80 psig max.
- Speeds:  
1800 rpm max.

For other operating conditions, consult John Crane Engineering.

## Design Features

- Maximum Flexibility — compression ring provides extreme flexibility. Shaft deflections, angular misalignments, and run outs are “tracked” by the seal without diminishing performance.
- No Springs — compression ring acts as the spring eliminating clogging problems seen in fibrous or abrasive services.
- Slotted Gland Plates — long slots on gland plates allow the seals to be fitted to numerous pumps and other rotating equipment without adaptors.
- Any Shaft Size Possible — the rotating assembly can be machined to fit any size shaft whether it is inch, metric, or special.
- No O-rings — wide sealing surface of the sealing ring prevents leaks even on the most worn, pitted shafts.
- Self-Aligning — the rotating assembly self-aligns itself square with the shaft for true running.
- Easy Installation — fewer parts and simple design allow for easy installation. Seal can be readily mounted on worn shafts and on out-of-square stuffing boxes. No modification of equipment is needed.
- Retaining ring ensures perfect face halves alignment and trouble-free startup.



# TYPE 37FS

## Fully Split Seal

### Type 37FS Typical Arrangement/Dimensional Data

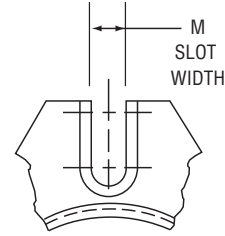
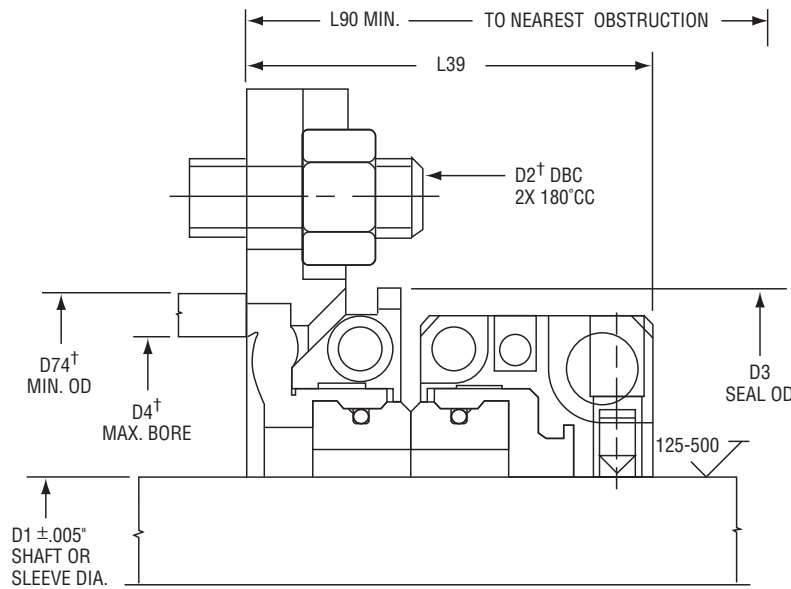

† Adaptive hardware designed for different arrangements.

### Type 37FS Dimensional Data (inches)

Shaft/Sleeve Size/D1 (inches)	D2	D3	D4	D74	M	SIC/SIC*	CAR/SIC**	L39	L90
1.375	3.750-5.000	3.642	2.406	3.000	.562	1.968	2.000	2.500	2.500
1.500	3.875-5.125	3.767	2.531	3.125	.562	1.968	2.000	2.500	2.500
1.625	4.000-5.250	3.892	2.656	3.250	.562	1.968	2.000	2.500	2.500
1.687	4.062-5.312	3.955	2.718	3.312	.562	1.968	2.000	2.500	2.500
1.750	4.125-5.375	4.017	2.781	3.375	.562	1.968	2.000	2.500	2.500
1.875	4.250-5.500	4.142	2.906	3.500	.562	1.968	2.000	2.500	2.500
1.937	4.312-5.562	4.205	2.968	3.562	.562	1.968	2.000	2.500	2.500
2.000	4.375-5.625	4.268	3.031	3.625	.562	1.968	2.000	2.500	2.500
2.125	4.500-5.750	4.393	3.156	3.750	.562	1.968	2.000	2.500	2.500
2.250	4.625-5.875	4.518	3.281	3.875	.562	1.968	2.000	2.500	2.500
2.375	4.750-6.000	4.643	3.406	4.000	.562	1.968	2.000	2.500	2.500
2.437	4.812-6.062	4.705	3.468	4.062	.562	1.968	2.000	2.500	2.500
2.500	4.875-6.125	4.768	3.531	4.125	.562	1.968	2.000	2.500	2.500
2.625	5.000-6.250	4.893	3.656	4.250	.562	1.968	2.000	2.500	2.500
2.750	5.125-6.375	5.018	3.781	4.375	.562	1.968	2.000	2.500	2.500
2.937	5.312-6.562	5.205	3.968	4.562	.562	1.968	2.000	2.500	2.500
3.000-3.250	6.500-8.500	5.450	4.812	5.375	.562	2.600	2.665	3.000	3.000
3.250-3.437	6.750-8.750	5.700	5.062	5.625	.562	2.600	2.665	3.000	3.000
3.437-3.812	7.625-10.125	6.137	5.500	6.062	.687	2.600	2.665	3.000	3.000
3.812-4.187	8.000-10.500	6.512	5.875	6.437	.687	2.600	2.665	3.000	3.000
4.187-4.562	8.375-10.875	6.887	6.250	6.812	.687	2.600	2.665	3.000	3.000
4.562-4.937	8.750-11.250	7.262	6.625	7.187	.687	2.600	2.665	3.000	3.000
4.937-5.312	9.125-11.625	7.637	7.000	7.562	.687	2.600	2.665	3.000	3.000
5.312-5.687	10.000-12.500	8.012	7.375	7.937	.812	2.600	2.665	3.000	3.000
5.687-6.062	10.375-12.875	8.387	7.750	8.312	.812	2.600	2.665	3.000	3.000
6.062-6.437	10.750-13.250	8.762	8.125	8.687	.812	2.600	2.665	3.000	3.000
6.437-6.812	11.125-13.625	9.137	8.500	9.062	.812	2.600	2.665	3.000	3.000
6.812-7.187	11.500-14.000	9.512	8.875	9.437	.812	2.600	2.665	3.000	3.000
7.187-7.562	11.625-14.625	10.137	9.250	9.812	.812	2.710	2.770	3.125	3.125
7.562-7.937	12.000-15.000	10.512	9.625	10.187	.812	2.710	2.770	3.125	3.125
7.937-8.312	12.375-15.375	10.887	10.000	10.562	.812	2.710	2.770	3.125	3.125
8.312-8.687	12.750-15.750	11.262	10.375	10.937	.812	2.710	2.770	3.125	3.125
8.687-9.062	13.500-16.500	11.637	10.750	11.312	.812	2.710	2.770	3.125	3.125
9.062-9.437	13.875-16.875	12.012	11.125	11.687	.812	2.710	2.770	3.125	3.125
9.437-9.812	14.250-17.250	12.387	11.500	12.062	.812	2.710	2.770	3.125	3.125
9.812-10.187	14.625-17.625	12.762	11.875	12.437	.812	2.710	2.770	3.125	3.125

\*SIC/SIC = Silicon Carbide vs. Silicon Carbide

\*\*CAR/SIC = Carbon vs. Silicon Carbide



# TYPE 37FS

## Fully Split Seal

### Basic Pressure Rating

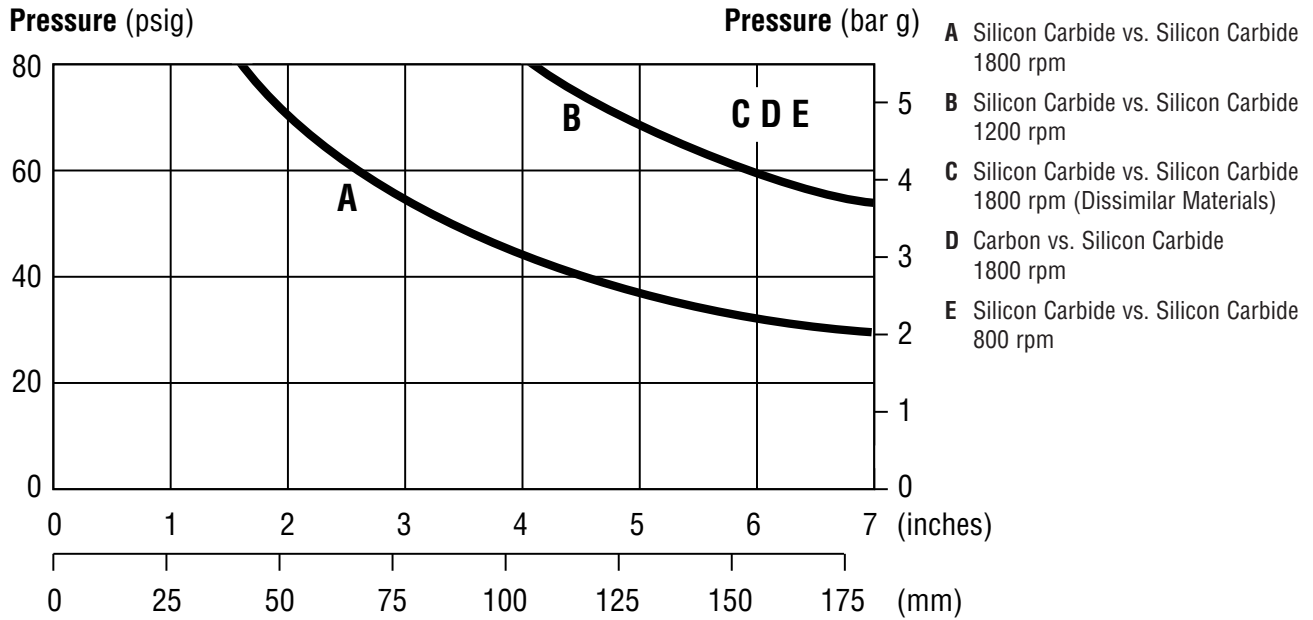

The Basic Pressure Rating is for a standard Type 37FS seal, as shown in the typical arrangement, when installed according to the criteria given in this data sheet and generally accepted industrial practices.

The Basic Pressure Rating assumes stable operation in a clean, cool, lubricating, nonvolatile liquid, with an adequate flush rate. For process services outside this range or a more precise assessment of the dynamic pressure rating, contact John Crane for more information.

### Materials of Construction

SEAL COMPONENTS	MATERIALS	
	Standard	Options
Primary Ring	Carbon Silicon Carbide	—
Mating Ring	Silicon Carbide	—
Secondary Sealing Element	Buna-N Ethylene Propylene	Fluoroelastomer TFE Propylene
Cord Segment	TFE Propylene	—
Retaining Ring	Inconel®	—
Clamp Ring Drive Ring Gland Plate Fasteners	316 Stainless Steel	—

Inconel is a registered trademark of the Special Metals Corporation Group of Companies



# TYPE 37FS

Fully Split Seal

## Criteria for Installation

Shaft/Sleeve	Limits
Shaft Surface Finish	125-500 RMS
Ovality/Out of Roundness (Shaft)	0.13 mm/0.005"
End Play/ Axial Float Allowance	±0.76 mm/0.030"
Axial Runout/ Out of Squareness	2.54 mm/0.100" TIR (Silicon Carbide vs. Silicon Carbide) 1.27 mm/0.050" TIR (Carbon vs. Silicon)

CUT LINE FOR SHORT PAGE



# TYPE 37FS

## Fully Split Seal

### Flexibility Specifications

#### 1. Seal chamber dimensions and finishes

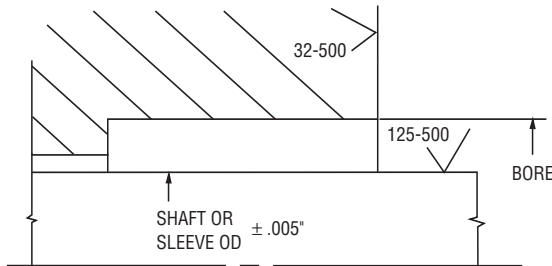

#### 2. Axial end play

Seal sizes 1.375" to 3.000" - 0.020" TIR max.  
 Seal sizes 3.000" to 10.000" - 0.060" TIR max.

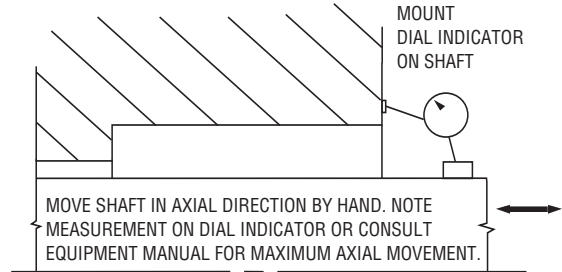

#### 3. Squareness of seal chamber face to shaft

Carbon vs. Silicon = 0.050" TIR max.  
 Silicon vs. Silicon = 0.100" TIR max.

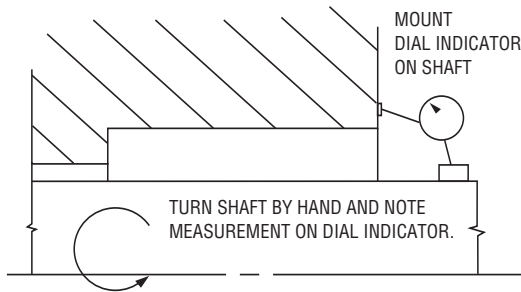

#### 4. Shaft runout (0.020" TIR max.)

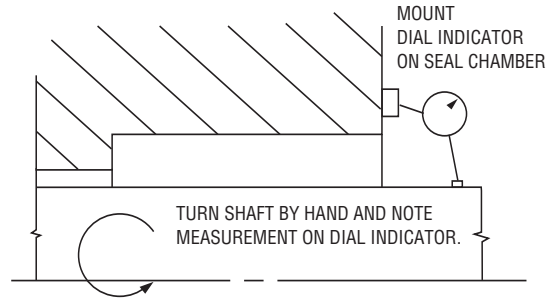

#### 5. Stuffing box face waviness (0.030" TIR max.)

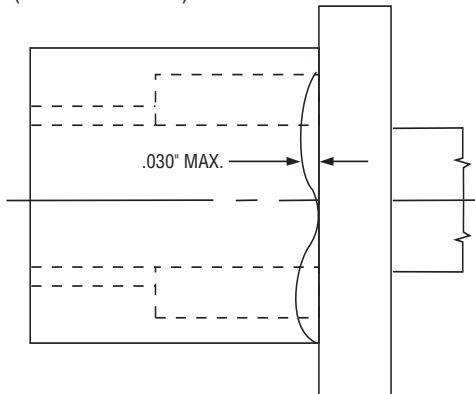

#### 6. Radial shaft movement (0.125" TIR max.)

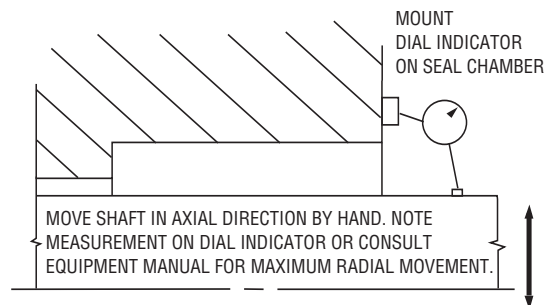

CUT LINE FOR SHORT PAGE



# TYPE 37FS

## Fully Split Seal

### Application Information

The Type 37FS Seal is custom-tailored to the application required. Applications must be reviewed by John Crane Engineering. The following data is necessary to evaluate the proposed application.

Customer's Name: \_\_\_\_\_ Location: \_\_\_\_\_

John Crane Salesman: \_\_\_\_\_ Phone # \_\_\_\_\_

#### 1. Equipment:

Type: \_\_\_\_\_ Manufacturer \_\_\_\_\_

Model: \_\_\_\_\_ Installation: Horizontal \_\_\_\_\_ Vertical: \_\_\_\_\_

If Vertical:  Top Entering or  Bottom Entering

#### 2. Application:

Process Fluid: \_\_\_\_\_ Specific Gravity: \_\_\_\_\_

Viscosity: \_\_\_\_\_ Vapor Pressure: \_\_\_\_\_

Injection Fluid: \_\_\_\_\_ Available Pressure: \_\_\_\_\_

Max. Allowable Pressure: \_\_\_\_\_ Max. Allowable Flow Rate: \_\_\_\_\_

#### 3. Operation:

Speed: \_\_\_\_\_ Temperature: \_\_\_\_\_ Stuffing Box Pressure: \_\_\_\_\_

Suction Pressure: \_\_\_\_\_ Discharge Pressure: \_\_\_\_\_

#### 4. Dimensions:

Sleeve OD (A) (if applicable): \_\_\_\_\_

Sleeve Extension (B) (if applicable): \_\_\_\_\_

Shaft/Sleeve Surface Finish: \_\_\_\_\_

Shaft OD (C): \_\_\_\_\_

Stuffing Box Bore (D): \_\_\_\_\_

Stuffing Box OD (E): \_\_\_\_\_

Bolt Circle Diameter (F): \_\_\_\_\_

Number & Size of Bolts (G, H): \_\_\_\_\_

Type of Bolts: (Circle Appropriate):

Swing Bolts:

Studs:  Removable? Yes  No

Tapped Holes:

Bolt Extension (I): \_\_\_\_\_

Nearest Obstruction (J): \_\_\_\_\_

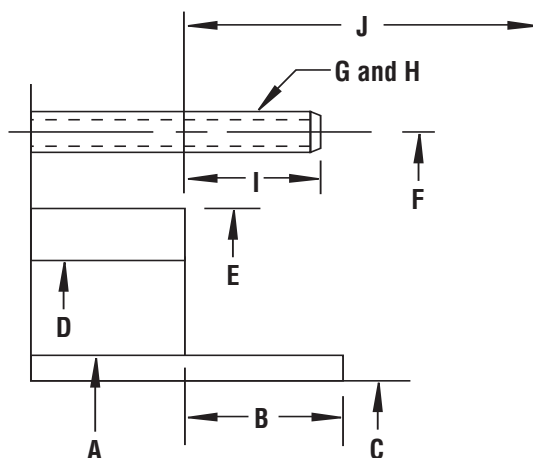

**Europe**  
Slough, UK

Tel: 44-1753-224000  
Fax: 44-1753-224224

**Latin America**  
São Paulo, Brazil

Tel: 55-11-3371-2500  
Fax: 55-11-3371-2599

**Middle East, Africa, Asia**  
Dubai, United Arab Emirates

Tel: 971-4-3438940  
Fax: 971-4-3438970

**North America**  
Morton Grove, Illinois USA

**1-800-SEALING**  
Tel: 1-847-967-2400  
Fax: 1-847-967-3915

smiths

For your nearest John Crane facility, please contact one of the locations above.

If the products featured will be used in a potentially dangerous and/or hazardous process, your John Crane representative should be consulted prior to their selection and use. In the interest of continuous development, John Crane Companies reserve the right to alter designs and specifications without prior notice. It is dangerous to smoke while handling products made from PTFE. Old and new PTFE products must not be incinerated.