

# SERVICE & OPERATING MANUAL



## Model U1F Metallic Design Level 1

### Table of Contents

Engineering Data and Temperature Limitations.....	1	Available Service and Conversion Kits .....	12
Explanation of Pump Nomenclature .....	2	Composite Repair Parts List.....	13
Performance Curve.....	3	Air Distribution Valve Assembly Drawing and Parts List.....	14
Dimensions .....	4	Air Distribution Valve Servicing.....	15
Metric Dimensions .....	5	Pilot Valve Servicing, Assembly Drawing & Parts List .....	16
Principle of Pump Operation.....	6	Diaphragm Service Drawing, with Overlay .....	17
Installation and Start-Up.....	6	Diaphragm Service Drawing, Non-Overlay.....	17
Air Supply .....	6	Diaphragm Servicing .....	18
Air Valve Lubrication .....	6	Overlay Diaphragm Servicing .....	18
Air Line Moisture.....	6	Actuator Plunger Servicing.....	19
Air Inlet and Priming .....	6	Check Valve Servicing .....	20
Between Uses .....	6	Check Valve Drawing.....	20
Installation Guide.....	7	Muffler Drawing and Provision for Piping Air Exhaust .....	21
Troubleshooting .....	8	Pumping Hazardous Liquids.....	21
Warranty .....	8	Converting Pump for Piping Exhaust Air .....	21
Recycling.....	9	Converted Exhaust Illustration.....	21
Important Safety Information .....	9	Grounding The Pump .....	22
Material Codes .....	10	CE Declaration of Conformity .....	23
Composite Repair Parts Drawing .....	12	ATEX Declaration of Conformity.....	24

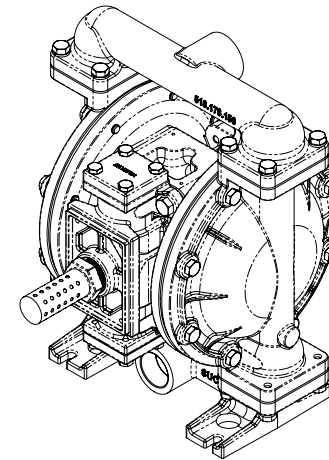

U.S. Patent #  
5,996,627  
Other U.S. Patents  
Applied for



**WARREN  
RUPP®**

Quality System  
ISO9001 Certified

Environmental  
Management System  
ISO14001 Certified

**IDEX**  
FLUID & METERING

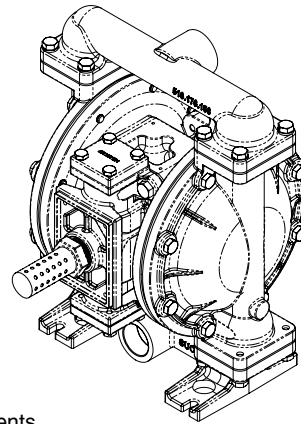

U.S. Patent #  
5,996,627  
Other U.S. Patents  
Applied for

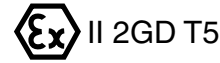

**SANDPIPER®**  
A WARREN RUPP PUMP BRAND

**U1F Metallic**  
**Air-Operated  
Double Diaphragm Pump**

ENGINEERING, PERFORMANCE  
& CONSTRUCTION DATA

<b>INTAKE/DISCHARGE PIPE SIZE</b> 1" NPT(internal) 1" BSPT Tapered (internal)	<b>CAPACITY</b> 0 to 45 gallons per minute (0 to 170 liters per minute)	<b>AIR VALVE</b> No-lube, no-stall design	<b>SOLIDS-HANDLING</b> Up to .25 in. (6mm)	<b>HEADS UP TO</b> 100 psi or 230.7 ft. of water (7 Kg/cm <sup>2</sup> or 70 meters)	<b>DISPLACEMENT/STROKE</b> .11 Gallon / .42 liter
---	---	---	---	--	--

**CAUTION! Operating temperature limitations are as follows:**

**Materials**

	Operating Temperatures	
	Maximum	Minimum
<b>Nitrile</b> General purpose, oil-resistant. Shows good solvent, oil, water and hydraulic fluid resistance. Should not be used with highly polar solvents like acetone and MEK, ozone, chlorinated hydrocarbons and nitro hydrocarbons.	190°F 88°C	-10°F -23°C
<b>Neoprene</b> All purpose. Resistant to vegetable oil. Generally not affected by moderate chemicals, fats, greases and many oils and solvents. Generally attacked by strong oxidizing acids, ketones, esters, nitro hydrocarbons and chlorinated aromatic hydrocarbons.	170°F 77°C	-10°F -23°C
<b>Virgin PTFE</b> Chemically inert, virtually impervious. Very few chemicals are known to react chemically with PTFE: molten alkali metals, turbulent liquid or gaseous fluorine and a few fluoro-chemicals such as chlorine trifluoride or oxygen difluoride which readily liberate free fluorine at elevated temperatures.	212°F 100°C	-35°F -37°C
<b>Polypropylene</b>	150°F 65°C	-40°F -40°C
<b>Polyethylene</b>	180°F 82°C	-40°F -40°C

For specific applications, always consult Warren Rupp's "Chemical Resistance Chart"

**SANDPIPER® pumps are designed to be powered only by compressed air.**

# Explanation of Pump Nomenclature

## U1F UL79 Listed Metallic · Design Level 1 · Ball Valve

MODEL	Pump Brand	Pump Size	Check Valve Type	Design Level	Wetted Material	Diaphragm/ Check Valve Materials	Check Valve Seat	Non-Wetted Material Options	Porting Options	Pump Style	Pump Options	Kit Options	Shipping Weight lbs. (kg)
U1F B1XBTXNS600.	U	1F	B	1	X	B	T	X	N	S	6	00.	53 (24)
U1F B1XGTXNS600.	U	1F	B	1	X	G	T	X	N	S	6	00.	53 (24)
U1FB1CBTCNS600.	U	1F	B	1	C	B	T	C	N	S	6	00.	53 (24)
U1FB1CGTCNS600.	U	1F	B	1	C	G	T	C	N	S	6	00.	53 (24)
U1F B1XBTXSS600.	U	1F	B	1	X	B	T	X	S	S	6	00.	53 (24)
U1F B1XGTXSS600.	U	1F	B	1	X	G	T	X	S	S	6	00.	53 (24)

**Pump Brand**

U=UL79 Listed SANDPIPER®

**Pump Size**

1F=1"

**Check Valve Type**

B= Ball

**Design Level**

1= Design Level

**Wetted Material**

X= Unpainted Aluminum

C= Conductive Painted Aluminum

**Diaphragm Check Valve Materials**

B= Nitrile/Nitrile

G= PTFE-Neoprene/PTFE

**Check Valve Seat**

T= PTFE

**Non-Wetted Material Options**

X= Unpainted Aluminum

C= Conductive Painted Aluminum

**Porting Options**

N=NPT Threads

B= BSPT (Tapered) Threads

S= NPT Suction Port Facing Air

Inlet, NPT Discharge Port Facing Air Exhaust

**Pump Style**

S= Standard

**Pump Options**

6= Metal Muffler

Model U1FB1XBTXNS600 is UL79 listed for pumping: Gasoline, Diesel Fuel, No. 4 Fuel Oils (or lighter), Motor Oil, Kerosene, Aviation Fuel and Water

Model U1FB1XGTXNS600 is UL79 listed for pumping: Gasoline (Including Alcohol Blends up to 15%), Diesel Fuel, Motor Oil, No. 4 Oil (or lighter), Kerosene, Aviation Fuel, Automatic Transmission Fluid, Alcohol, Water, Waste Oil, Ethyl Alcohol, Methyl Alcohol and Ethylene Glycol.



⚠ **WARNING**

*In the event of diaphragm rupture, pumped material may enter the air end of the pump, and be discharged into the atmosphere. If pumping a product which is hazardous or toxic, the air exhaust must be piped to an appropriate area for safe disposition.*

# Performance Curve, U1F UL79 Listed Metallic Design Level 1

## MODEL U1F Metallic Performance Curve

Performance based on the following: elastomer fitted pump, flooded suction, water at ambient conditions.  
 The use of other materials and varying hydraulic conditions may result in deviations in excess of 5%.

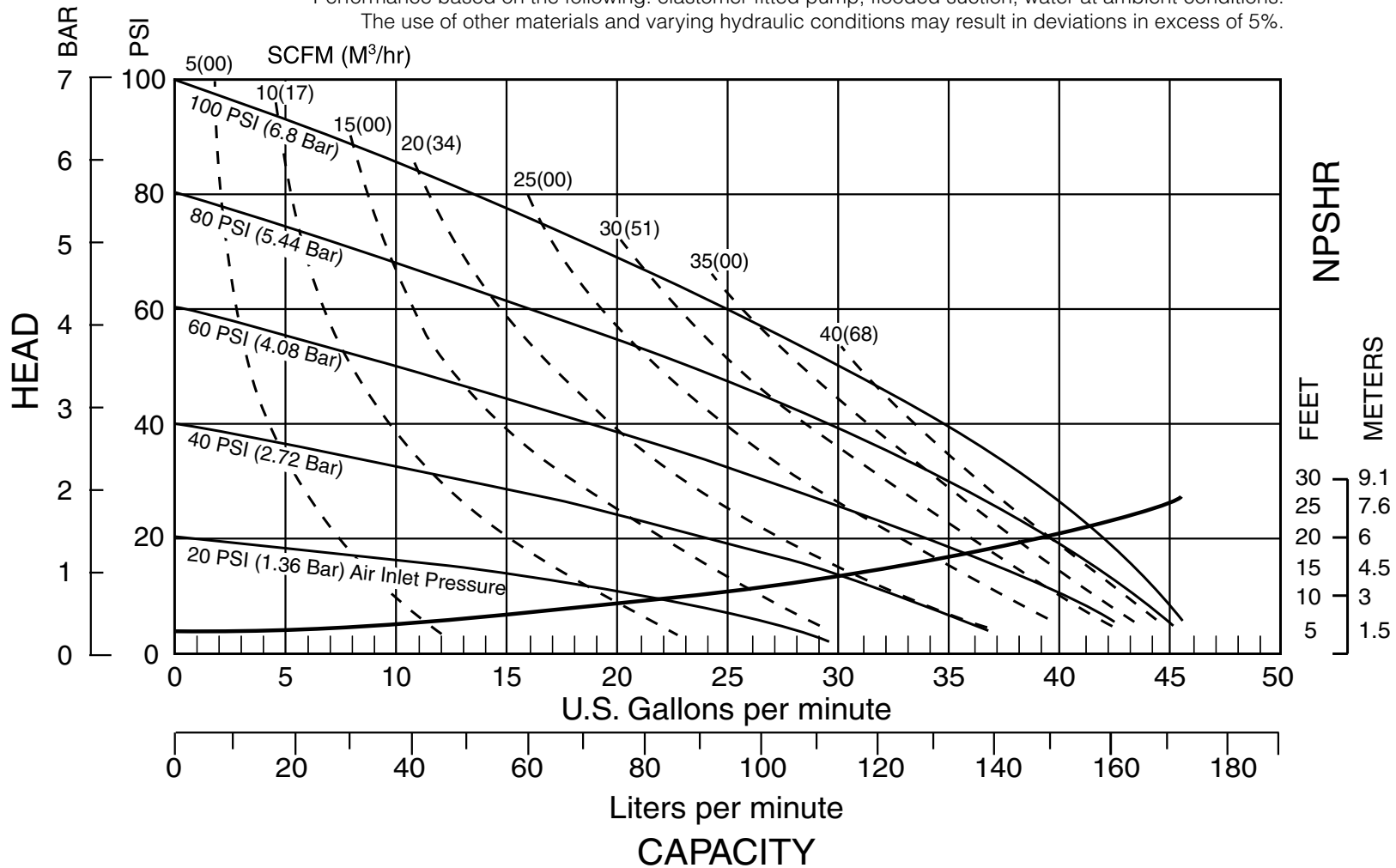

# Dimensions: U1F UL79 LISTED Metallic

Dimensions in Inches

Dimensional Tolerance:  $\pm 1/8$ "

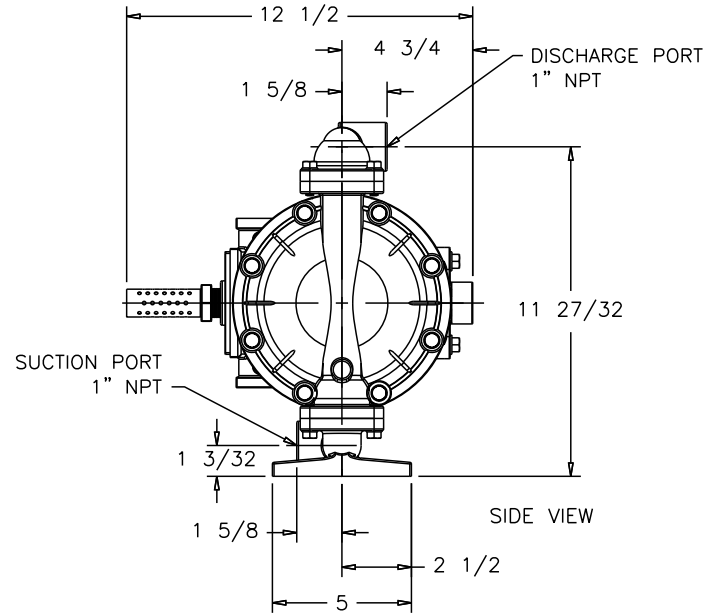
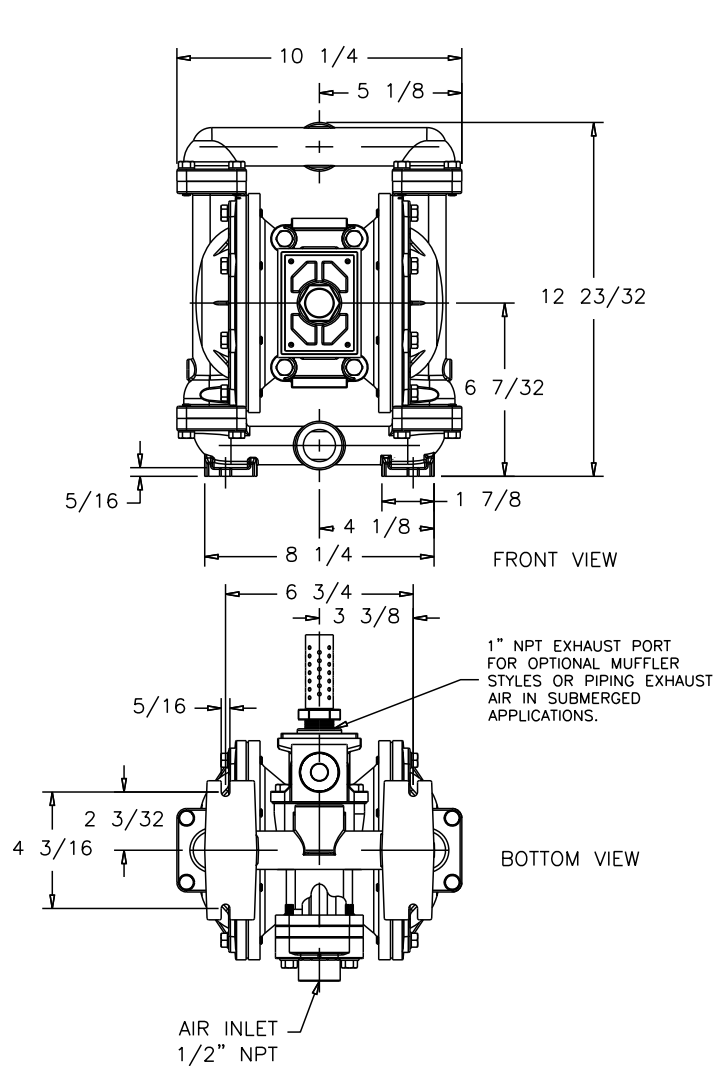

MODELS U1F

DIMENSIONS IN INCHES

DIMENSIONAL TOLERANCE:  $\pm 1/8$

WITH 530-033-000 MUFFLER

BOTH SUCTION AND DISCHARGE PORTS ARE AVAILABLE WITH 1" BSPT TAPERED THREADS

# Metric Dimensions: U1F UL79 Listed Metallic

Dimensions in Millimeters  
Dimensional Tolerance: ± 3mm

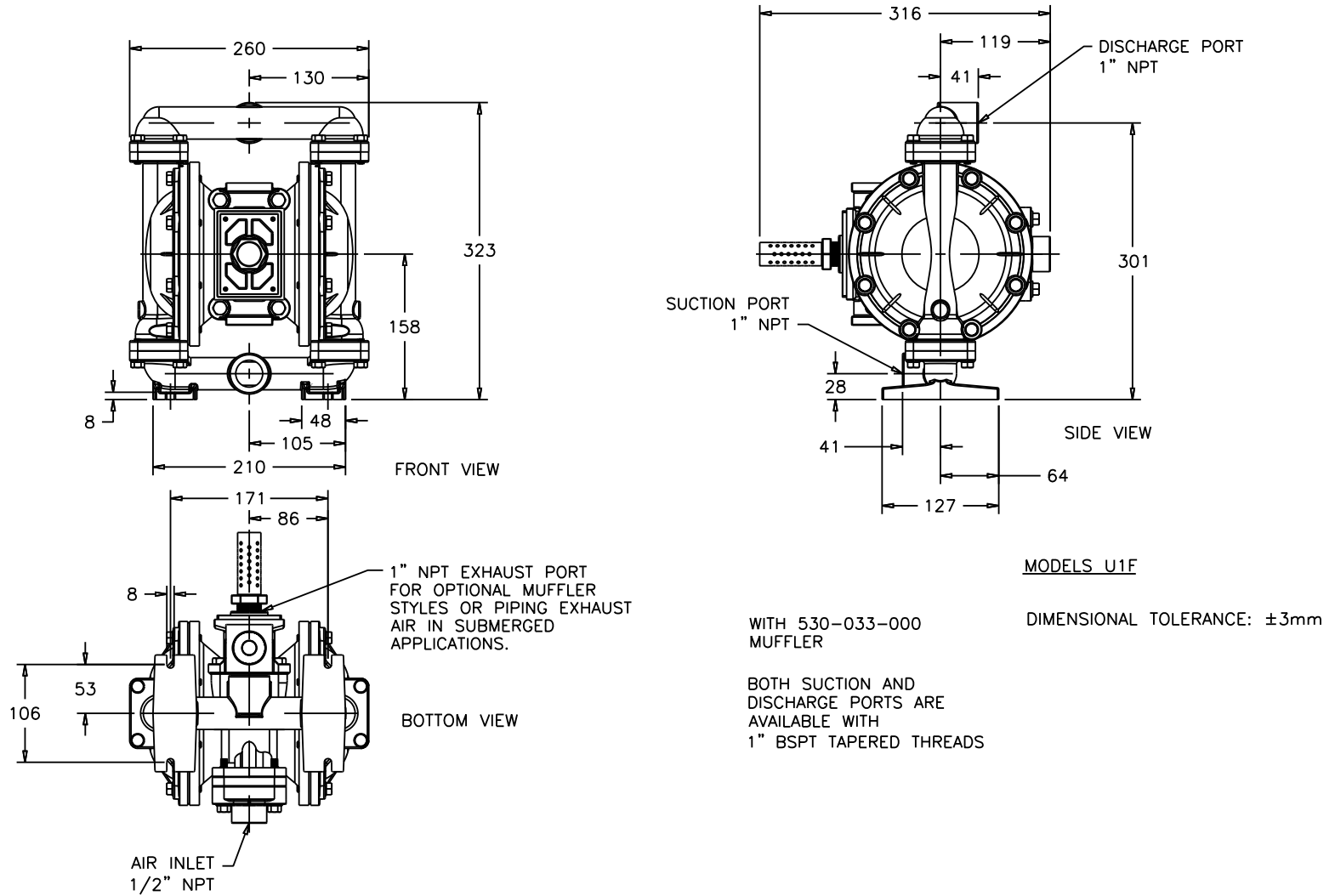

## **PRINCIPLE OF PUMP OPERATION**

This ball type check valve pump is powered by compressed air and is a 1:1 ratio design. The inner side of one diaphragm chamber is alternately pressurized while simultaneously exhausting the other inner chamber. This causes the diaphragms, which are connected by a common rod secured by plates to the centers of the diaphragms, to move in a reciprocating action. (As one diaphragm performs the discharge stroke the other diaphragm is pulled to perform the suction stroke in the opposite chamber.) Air pressure is applied over the entire inner surface of the diaphragm while liquid is discharged from the opposite side of the diaphragm. The diaphragm operates in a balanced condition during the discharge stroke which allows the pump to be operated at discharge heads over 200 feet (61 meters) of water.

For maximum diaphragm life, keep the pump as close to the liquid being pumped as possible. Positive suction head in excess of 10 feet of liquid (3.048 meters) may require a back pressure regulating device to maximize diaphragm life.

Alternate pressurizing and exhausting of the diaphragm chamber is performed by an externally mounted, pilot operated, four way spool type air distribution valve. When the spool shifts to one end of the valve body, inlet pressure is applied to one diaphragm chamber and the other diaphragm chamber exhausts. When the spool shifts to the opposite end of the valve body, the pressure to the chambers is

reversed. The air distribution valve spool is moved by an internal pilot valve which alternately pressurizes one end of the air distribution valve spool while exhausting the other end. The pilot valve is shifted at each end of the diaphragm stroke when an actuator plunger is contacted by the diaphragm plate. This actuator plunger then pushes the end of the pilot valve spool into position to activate the air distribution valve.

The chambers are connected with manifolds with a suction and discharge check valve for each chamber, maintaining flow in one direction through the pump.

## **INSTALLATION AND START-UP**

Locate the pump as close to the product being pumped as possible. Keep the suction line length and number of fittings to a minimum. Do not reduce the suction line diameter.

For installations of rigid piping, short sections of flexible conductive hose should be installed between the pump and the piping. The flexible conductive hose reduces vibration and strain to the pumping system. A surge suppressor is recommended to further reduce pulsation in flow.

## **AIR SUPPLY**

Air supply pressure cannot exceed 125 psi (8.6 bar). Connect the pump air inlet to an air supply of sufficient capacity and pressure required for desired performance. When the air supply line is solid piping, use a short length of flexible conductive hose not less than 1/2" (13mm) in diameter between the

pump and the piping to reduce strain to the piping. The weight of the air supply line, regulators and filters must be supported by some means other than the air inlet cap. Failure to provide support for the piping may result in damage to the pump. A pressure regulating valve should be installed to insure air supply pressure does not exceed recommended limits.

## **AIR VALVE LUBRICATION**

The air distribution valve and the pilot valve are designed to operate WITHOUT lubrication. This is the preferred mode of operation. There may be instances of personal preference or poor quality air supplies when lubrication of the compressed air supply is required. The pump air system will operate with properly lubricated compressed air supply. Proper lubrication requires the use of an air line lubricator (available from Warren Rupp) set to deliver one drop of SAE 10 non-detergent oil for every 20 SCFM (9.4 liters/sec.) of air the pump consumes at the point of operation. Consult the pump's published Performance Curve to determine this.

## **AIR LINE MOISTURE**

Water in the compressed air supply can create problems such as icing or freezing of the exhaust air, causing the pump to cycle erratically or stop operating. Water in the air supply can be reduced by using a point-of-use air dryer to supplement the user's air drying equipment. This device removes water from the compressed air supply and alleviates the icing or freezing problems.

## **AIR INLET AND PRIMING**

To start the pump, open the air valve approximately 1/2" to 3/4" turn. After the pump primes, the air valve can be opened to increase air flow as desired. If opening the valve increases cycling rate, but does not increase the rate of flow, cavitation has occurred. The valve should be closed slightly to obtain the most efficient air flow to pump flow ratio.

## **BETWEEN USES**

When the pump is used for materials that tend to settle out or solidify when not in motion, the pump should be flushed after each use to prevent damage. (Product remaining in the pump between uses could dry out or settle out. This could cause problems with the diaphragms and check valves at restart.) In freezing temperatures the pump must be completely drained between uses in all cases.

## INSTALLATION GUIDE Top Discharge Ball Valve Pump

- ① Surge Suppressor
- ② Filter/Regulator
- ③ Air Dryer

### ⚠ CAUTION

Use a gasoline-resistant pipe compound to make pipe joints tight.

Pump shall be installed in accordance to Flammable and Combustible Liquids Code, NFPA 30 or the Automotive and Marine Service Station Code, NFPA 30A, as appropriate to the intended use of the pump.

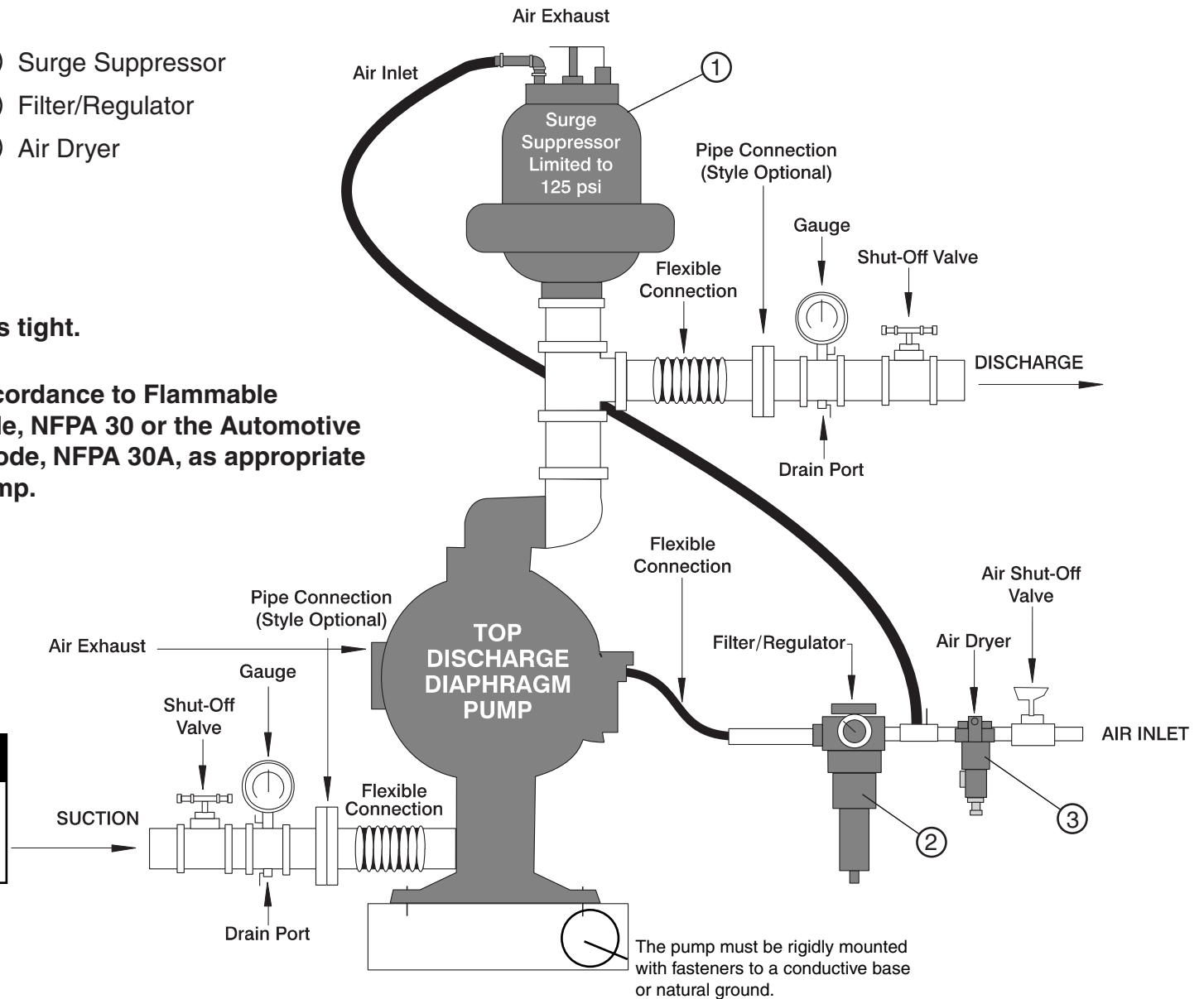
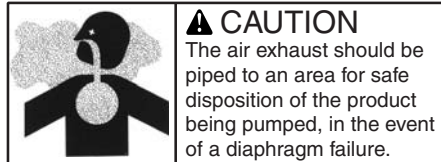

## TROUBLESHOOTING

### Possible Symptoms:

- Pump will not cycle.
- Pump cycles, but produces no flow.
- Pump cycles, but flow rate is unsatisfactory.
- Pump cycle seems unbalanced.
- Pump cycle seems to produce excessive vibration.

**What to Check:** Excessive suction lift in system.

**Corrective Action:** For lifts exceeding 20 feet (6 meters), filling the pumping chambers with liquid will prime the pump in most cases.

**What to Check:** Excessive flooded suction in system.

**Corrective Action:** For flooded conditions exceeding 10 feet (3 meters) of liquid, install a back pressure device.

**What to Check:** System head exceeds air supply pressure.

**Corrective Action:** Increase the inlet air pressure to the pump. Most diaphragm pumps are designed for 1:1 pressure ratio at zero flow.

**What to Check:** Air supply pressure or volume exceeds system head.

**Corrective Action:** Decrease inlet air pressure and volume to the pump as calculated on the published PERFORMANCE CURVE. Pump is cavitating the fluid by fast cycling.

**What to Check:** Undersized suction line.

**Corrective Action:** Meet or exceed pump connection recommendations shown on the DIMENSIONAL DRAWING.

**What to Check:** Restricted or undersized air line.

**Corrective Action:** Install a larger air line and connection. Refer to air inlet recommendations shown in your pump's SERVICE MANUAL.

**What to Check:** Check ESADS, the Externally Serviceable Air Distribution System of the pump.

**Corrective Action:** Disassemble and inspect the main air distribution valve, pilot valve and pilot valve actuators. Refer to the parts drawing and air valve section of the SERVICE MANUAL. Check for clogged discharge or closed valve before reassembly.

**What to Check:** Rigid pipe connections to pump.

**Corrective Action:** Install flexible connectors and a surge suppressor.

**What to Check:** Blocked air exhaust muffler.

**Corrective Action:** Remove muffler screen, clean or de-ice and reinstall. Refer to the Air Exhaust section of your pump SERVICE MANUAL.

**What to Check:** Pumped fluid in air exhaust muffler.

**Corrective Action:** Disassemble pump chambers. Inspect for diaphragm rupture or loose diaphragm plate assembly. Refer to the Diaphragm Replacement section of your pump SERVICE MANUAL.

**What to Check:** Suction side air leakage or air in product.

**Corrective Action:** Visually inspect all suction side gaskets and pipe connections.

**What to Check:** Obstructed check valve.

**Corrective Action:** Disassemble the wet end of the pump and manually dislodge obstruction in the check valve pocket. Refer to the Check Valve section of the pump SERVICE MANUAL for disassembly instructions.

**What to Check:** Worn or misaligned check valve or check valve seat.

**Corrective Action:** Inspect check valves and seats for wear and proper seating. Replace if necessary. Refer to Check Valve section of the pump SERVICE MANUAL for disassembly instructions.

**What to Check:** Blocked suction line.

**Corrective Action:** Remove or flush obstruction. Check and clear all suction screens and strainers.

**What to Check:** Blocked discharge line.

**Corrective Action:** Check for obstruction or closed discharge line valves.

**What to Check:** Blocked pumping chamber.

**Corrective Action:** Disassemble and inspect the wetted chambers of the pump. Remove or flush any obstructions. Refer to the pump SERVICE MANUAL for disassembly instructions.

**What to Check:** Entrained air or vapor lock in one or both pumping chambers.

**Corrective Action:** Purge chambers through tapped chamber vent plugs. PURGING THE CHAMBERS OF AIR CAN BE DANGEROUS! Contact the Warren Rupp Technical Services Department before performing this procedure. Any model with top-ported discharge will reduce or eliminate problems with entrained air.

If your pump continues to perform below your expectations, contact your local Warren Rupp Distributor or factory Technical Services Group for a service evaluation.

## WARRANTY

Refer to the enclosed Warren Rupp Warranty Certificate.

# RECYCLING

Many components of SANDPIPER® Metallic AODD pumps are made of recyclable materials (see chart on page 10 for material specifications). We encourage pump users to recycle worn out parts and pumps whenever possible, after any hazardous pumped fluids are thoroughly flushed.

Pump complies with EN809 Pumping Directive and Directive 98/37/EC Safety of Machinery, and Directive 94/9/EC, EN 13463-1 Equipment for use in potentially Explosive Environments. For reference to the directive certificates visit: [www.warrenrupp.com](http://www.warrenrupp.com). The Technical File AX1 is stored at KEMA, Notified Body 0344, under Document #203040000.



Underwriters Laboratories, Inc., an Internationally recognized independent organization for testing products to ensure public safety.

# IMPORTANT SAFETY INFORMATION



## IMPORTANT

Read these safety warnings and instructions in this manual completely, before installation and start-up of the pump. It is the responsibility of the purchaser to retain this manual for reference. Failure to comply with the recommendations stated in this manual will damage the pump, and void factory warranty.



## CAUTION

Before pump operation, inspect all gasketed fasteners for looseness caused by gasket creep. Retorque loose fasteners to prevent leakage. Follow recommended torques stated in this manual.



## WARNING

Before maintenance or repair, shut off the compressed air line, bleed the pressure, and disconnect the air line from the pump. The discharge line may be pressurized and must be bled of its pressure.



## WARNING

In the event of diaphragm rupture, pumped material may enter the air end of the pump, and be discharged into the atmosphere. If pumping a product which is hazardous or toxic, the air exhaust must be piped to an appropriate area for safe disposition.



## WARNING

Take action to prevent static sparking. Fire or explosion can result, especially when handling flammable liquids. The pump, piping, valves, containers or other miscellaneous equipment must be grounded. (See page 22)



## WARNING

This pump is pressurized internally with air pressure during operation. Always make certain that all bolting is in good condition and that all of the correct bolting is reinstalled during assembly.



## WARNING

When used for toxic or aggressive fluids, the pump should always be flushed clean prior to disassembly.



## WARNING

Before doing any maintenance on the pump, be certain all pressure is completely vented from the pump, suction, discharge, piping, and all other openings and connections. Be certain the air supply is locked out or made non-operational, so that it cannot be started while work is being done on the pump. Be certain that approved eye protection and protective clothing are worn all times in the vicinity of the pump. Failure to follow these recommendations may result in serious injury or death.



## WARNING

Airborne particles and loud noise hazards. Wear ear and eye protection.

# MATERIAL CODES

## The Last 3 Digits of Part Number

000	Assembly, sub-assembly; and some purchased items	175	Die Cast Zinc	374	Carboxylated Nitrile	604	PTFE
010	Cast Iron	180	Copper Alloy	375	Fluorinated Nitrile	606	PTFE
012	Powered Metal	305	Carbon Steel, Black Epoxy Coated	377	Conductive HNBR	607	Envelon
015	Ductile Iron	306	Carbon Steel, Black PTFE Coated	378	High Density Polypropylene	608	Conductive PTFE
020	Ferritic Malleable Iron	307	Aluminum, Black Epoxy Coated	379	Conductive Nitrile	610	PTFE Encapsulated Silicon
025	Music Wire	308	Stainless Steel, Black PTFE Coated	405	Cellulose Fibre	611	PTFE Encapsulated Viton
080	Carbon Steel, AISI B-1112	309	Aluminum, Black PTFE Coated	408	Cork and Neoprene	632	Neoprene/Hytrel
100	Alloy 20	310	Kynar Coated	425	Compressed Fibre	633	FKM/PTFE
110	Alloy Type 316 Stainless Steel	330	Zinc Plated Steel	426	Blue Gard	634	EPDM/PTFE
111	Alloy Type 316 Stainless Steel (Electro Polished)	331	Chrome Plated Steel	440	Vegetable Fibre	635	Neoprene/PTFE
112	Alloy "C" (Hastelloy equivalent)	332	Aluminum, Electroless Nickel Plated	465	Fibre	637	PTFE , Viton/PTFE
113	Alloy Type 316 Stainless Steel (Hand Polished)	333	Carbon Steel, Electroless Nickel Plated	500	Delrin 500	638	PTFE , Hytrel/PTFE
114	303 Stainless Steel	335	Galvanized Steel	501	Delrin 570	639	Nitrile/TFE
115	302/304 Stainless Steel	336	Zinc Plated Yellow Brass	502	Conductive Acetal, ESD-800	643	Santoprene®/EPDM
117	440-C Stainless Steel (Martensitic)	337	Silver Plated Steel	503	Conductive Acetal, Glass-Filled	644	Santoprene®/PTFE
120	416 Stainless Steel (Wrought Martensitic)	340	Nickel Plated	505	Acrylic Resin Plastic	656	Santoprene Diaphragm and Check Balls/EPDM Seats
123	410 Stainless Steel (Wrought Marten- sitic)	342	Filled Nylon	506	Delrin 150	661	EPDM/Santoprene
148	Hardcoat Anodized Aluminum	353	Geolast; Color: Black	520	Injection Molded PVDF Natural color	760	UL Listed or Approved Nitrile Compounds
149	2024-T4 Aluminum	354	Injection Molded #203-40 Santoprene- Duro 40D +/-5; Color: RED	540	Nylon		
150	6061-T6 Aluminum	355	Thermal Plastic	541	Nylon		
151	6063-T6 Aluminum	356	Hytrel	542	Nylon		
152	2024-T4 Aluminum (2023-T351)	357	Injection Molded Polyurethane	544	Nylon Injection Molded		Delrin and Hytrel are registered tradenames of E.I. DuPont.
154	Almag 35 Aluminum	358	Urethane Rubber (Some Applications) (Compression Mold)	550	Polyethylene		Gylon is a registered tradename of Garlock, Inc.
155	356-T6 Aluminum	359	Urethane Rubber	551	Glass Filled Polypropylene		Nylatron is a registered tradename of Polymer Corp.
156	356-T6 Aluminum	360	Nitrile Rubber. Color coded: RED	552	Unfilled Polypropylene		Santoprene is a registered tradename of Monsanto Corp.
157	Die Cast Aluminum Alloy #380	361	Nitrile	553	Unfilled Polypropylene		Rulon II is a registered tradename of Dixion Industries Corp.
158	Aluminum Alloy SR-319	362	FKM (Flouorocarbon): Color coded: YELLOW	555	Polyvinyl Chloride		Hastelloy-C is a registered tradename of Cabot Corp.
159	Anodized Aluminum	364	E.P.D.M. Rubber. Color coded: BLUE	556	Black Vinyl		Ryton is a registered tradename of Phillips Chemical Co.
162	Brass, Yellow, Screw Machine Stock	365	Neoprene Rubber. Color coded: GREEN	570	Rulon II		Valox is a registered tradename of General Electric Co.
165	Cast Bronze, 85-5-5-5	366	Food Grade Nitrile	580	Ryton		Warren Rupp, SANDPIPER, PortaPump, Tranquillizer and SludgeMaster are registered tradenames of Warren Rupp, Inc.
166	Bronze, SAE 660	368	Food Grade EPDM	590	Valox		
170	Bronze, Bearing Type, Oil Impregnated	370	Butyl Rubber. Color coded: BROWN	591	Nylatron G-S		
		371	Philthane (Tuftane)	592	Nylatron NSB		
				600	PTFE (virgin material) Tetrafluorocarbon (TFE)		
				601	PTFE (Bronze and moly filled)		
				602	Filled PTFE		
				603	Blue Gylon		



# Composite Repair Parts Drawing

**Add Kits:**  
476-230-000

**AIR END KIT (Available Service Kits:)**

**Air End Kit**  
Seals, O-Rings, Gaskets, Retaining Rings, Air Valve Assembly and Pilot Valve Assembly

476-213-760

**Wetted End Kit**

Nitrile Diaphragms, Nitrile Check Balls and PTFE Check Valve Seats

476-213-635

**Wetted End Kit**

Neoprene Backup Diaphragms, PTFE Overlay Diaphragms, PTFE Check Balls and PTFE Check Valve Seat

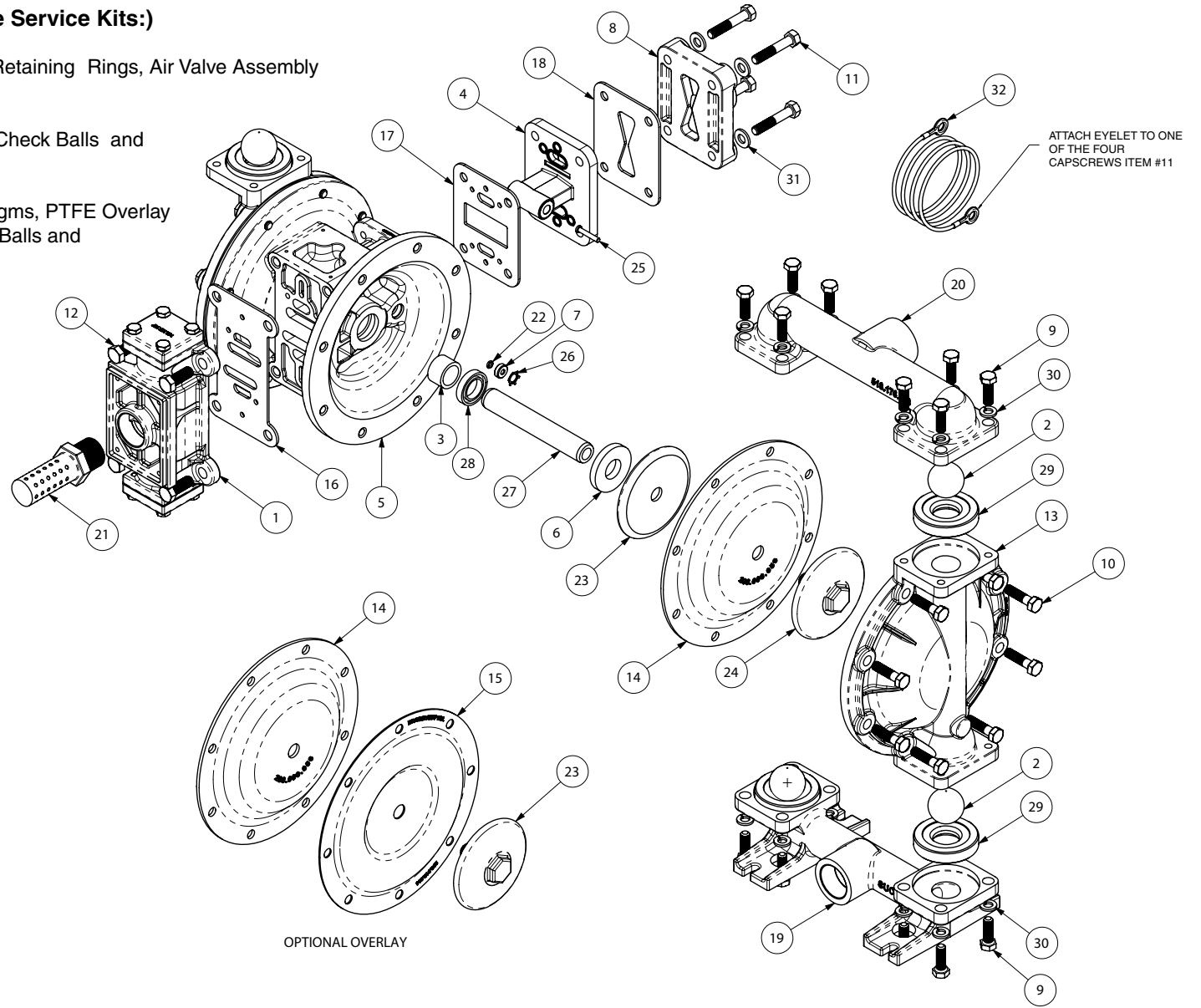

# Composite Repair Parts List

ITEM	PART NUMBER	DESCRIPTION	QTY	ITEM	PART NUMBER	DESCRIPTION	QTY
1	031-183-000	Air Valve Assembly	1	17	360-103-360	Gasket, Pilot Valve	1
2	050-028-760	Ball, Check	4	18	360-104-379	Gasket, Air Inlet	1
	050-028-600	Ball, Check	4	19	518-175-156	Manifold, Suction	1
3	070-012-170	Bushing	2		518-175-156E	Manifold, Suction 1" BSPT (Tapered)	1
4	095-110-000	Pilot Valve Assembly	1	20	518-176-156	Manifold, Discharge	1
5	114-025-157	Intermediate	1		518-176-156E	Manifold, Discharge 1" BSPT (Tapered)	1
6	132-019-360	Bumper	2	21	530-033-000	Metal Muffler	1
7	135-036-506	Bushing	2	22	560-001-379	O-Ring	2
8	165-120-157	Cap, Air Inlet Assembly	1	23	612-022-330	Plate, Inner Diaphragm	2
9	170-044-330	Capscrew, Hex Hd 5/16-18 X 1.00	16	24	612-108-157	Plate, Outer Diaphragm Assembly	2
10	170-045-330	Capscrew, Hex Hd 5/16-18 X 1.25	16	25	620-022-115	Pin, Actuator	2
11	170-069-330	Capscrew, Hex Hd 5/16-18 X 1.75	4	26	675-042-115	Ring, Retaining	2
12	170-006-330	Capscrew, Hex Hd 3/8-16 X 1.00	4	27	685-060-120	Rod, Diaphragm	1
13	196-173-156	Chamber, Outer	2	28	720-010-375	Seal, U-Cup	2
14	286-008-760	Diaphragm	2	29	722-098-600	Seat, Check Ball	4
	286-008-365	Diaphragm	2	30	900-004-330	Lockwasher	16
15	286-015-604	Diaphragm, Overlay	2	31	901-038-330	Flatwasher	4
16	360-093-360	Gasket, Air Valve	1	32	920-025-000	Ground Strap	1

# Air Valve Assembly Drawing, Parts List

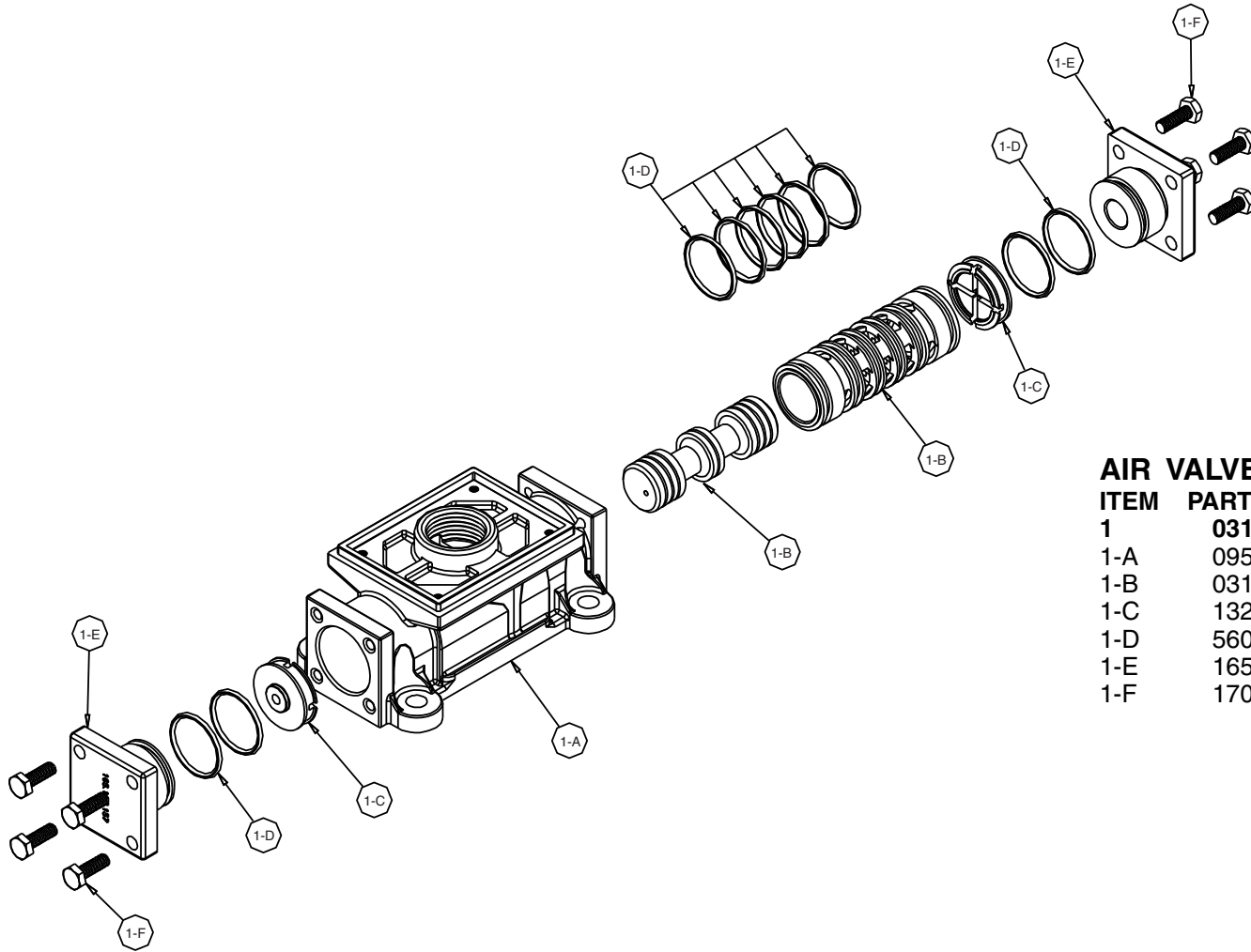

## AIR VALVE ASSEMBLY PARTS LIST

ITEM	PART NUMBER	DESCRIPTION	QTY
1	031-183-000	Gas Valve Assembly	1
1-A	095-109-157	Valve Body	1
1-B	031-139-000	Sleeve and Spool Set	1
1-C	132-029-357	Bumper	2
1-D	560-020-360	O-Ring	10
1-E	165-127-157	Cap, End	2
1-F	170-032-330	Capscrew	8

## AIR DISTRIBUTION VALVE SERVICING

To service the air valve first shut off the compressed air, bleed pressure from the pump, and disconnect the air supply line from the pump.

### **STEP #1:** See COMPOSITE REPAIR PARTS DRAWING.

Using a 9/16" wrench or socket, remove the four hex head capscrews (item 10). Remove the air valve assembly from the pump.

Remove and inspect gasket (item 16) for cracks or damage. Replace gasket if needed.

### **STEP #2:** Disassembly of the air valve.

Using a 7/16" wrench or socket, remove the eight hex capscrews (item 1-F) that fasten the end caps to the valve body.

Next remove the two end caps (items 1-E). Inspect two o-rings (items 1-D) on each end cap for damage or wear. Replace the o-rings as needed.

Remove the bumpers (items 1-C). Inspect the bumpers for damage or wear.

Remove the spool (part of item 1-A) from the sleeve. Be careful not to scratch or damage the outer diameter of the spool. Wipe spool with a soft cloth and inspect for scratches or wear.

Inspect the inner diameter of the sleeve (part of item 1-A) for dirt, scratches, or other contaminants. Remove the sleeve if needed and replace with a new sleeve and spool set (item 1-A).

### **STEP #3:** Reassembly of the air valve.

Install one bumper (item 1-C) and one end cap (item 1-E) with two o-rings (item 1-D) and fasten with four hex capscrews (items 1-F) to the valve body (items 1-A).

Remove the new sleeve and spool set (item 1-A) from the plastic bag. Carefully remove the spool from the sleeve. Install the six o-rings (item 1-G) into the six grooves on the sleeve. Apply a light coating of grease to the o-rings before installing the sleeve into the valve body (item 1-B), align the slots in the sleeve with the slots in the valve body. Insert the spool into the sleeve. Be careful not to scratch or damage the spool during installation. Push the spool in until it touches the bumper on the opposite end.

Install the remaining bumper, end cap (with o-rings), and fasten with the remaining hex capscrews.

Fasten the air valve assembly (item 1) and gasket (item 16) to the pump.

Connect the compressed air line to the pump. The pump is now ready for operation.



## **! IMPORTANT**

*Read these instructions completely, before installation and start-up. It is the responsibility of the purchaser to retain this manual for reference. Failure to comply with the recommendations stated in this manual will damage the pump, and void factory warranty.*

# Pilot Valve Servicing, Assembly Drawing & Parts List

## PILOT VALVE ASSEMBLY PARTS LIST

ITEM	PART NUMBER	DESCRIPTION	QTY
4	095-110-000	Pilot Valve Assembly	1
4-A	095-095-157	Valve Body	1
4-B	755-052-000	Sleeve (With O-rings)	1
4-C	560-033-360	O-ring (Sleeve)	6
4-D	775-055-000	Spool (With O-rings)	1
4-E	560-023-360	O-ring (Spool)	3
4-F	675-037-080	Retaining Ring	1

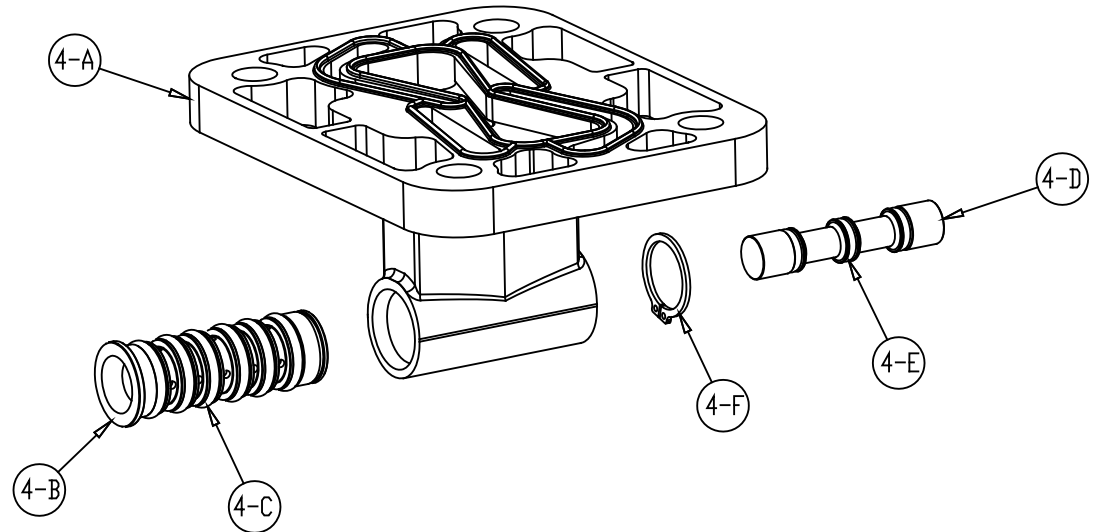

### PILOT VALVE SERVICING

To service the pilot valve first shut off the compressed air supply, bleed the pressure from the pump, and disconnect the air supply line from the pump.

**STEP #1:** See pump assembly drawing.

Using a 1/2" wrench or socket, remove the four capscrews (item 12). Remove the air inlet cap (item 8) and air inlet gasket (item 18). The pilot valve assembly (item 4) can now be removed for inspection and service.

**STEP #2:** Disassembly of the pilot valve.

Remove the pilot valve spool (item 4-D). Wipe clean and inspect spool and o-rings for dirt, cuts or wear. Replace the o-rings and spool if necessary.

Remove the retaining ring (item 4-F) from the end of the sleeve (item 4-B) and remove the sleeve from the valve body (item 4-A). Wipe clean and inspect sleeve and o-rings for dirt, cuts or wear. Replace the o-rings and sleeve if necessary.

**STEP #3:** Re-assembly of the pilot valve.

Generously lubricate outside diameter of the sleeve and o-rings. Then carefully insert sleeve into valve body. Take CAUTION when inserting sleeve, not to shear any o-rings. Install retaining ring to sleeve. Generously lubricate outside diameter of spool and o-rings. Then carefully insert spool into sleeve. Take CAUTION when inserting spool, not to shear any o-rings. Use BP-LS-EP-2 multipurpose grease, or equivalent.

**STEP #4:** Re-install the pilot valve assembly into the intermediate.

Be careful to align the ends of the pilot valve stem between the plunger pins when inserting the pilot valve into the cavity of the intermediate.

Re-install the gasket, air inlet cap and capscrews. Connect the air supply to the pump. The pump is now ready for operation.

# Diaphragm Service Drawing, with Overlay

# Diaphragm Service Drawing, Non-Overlay

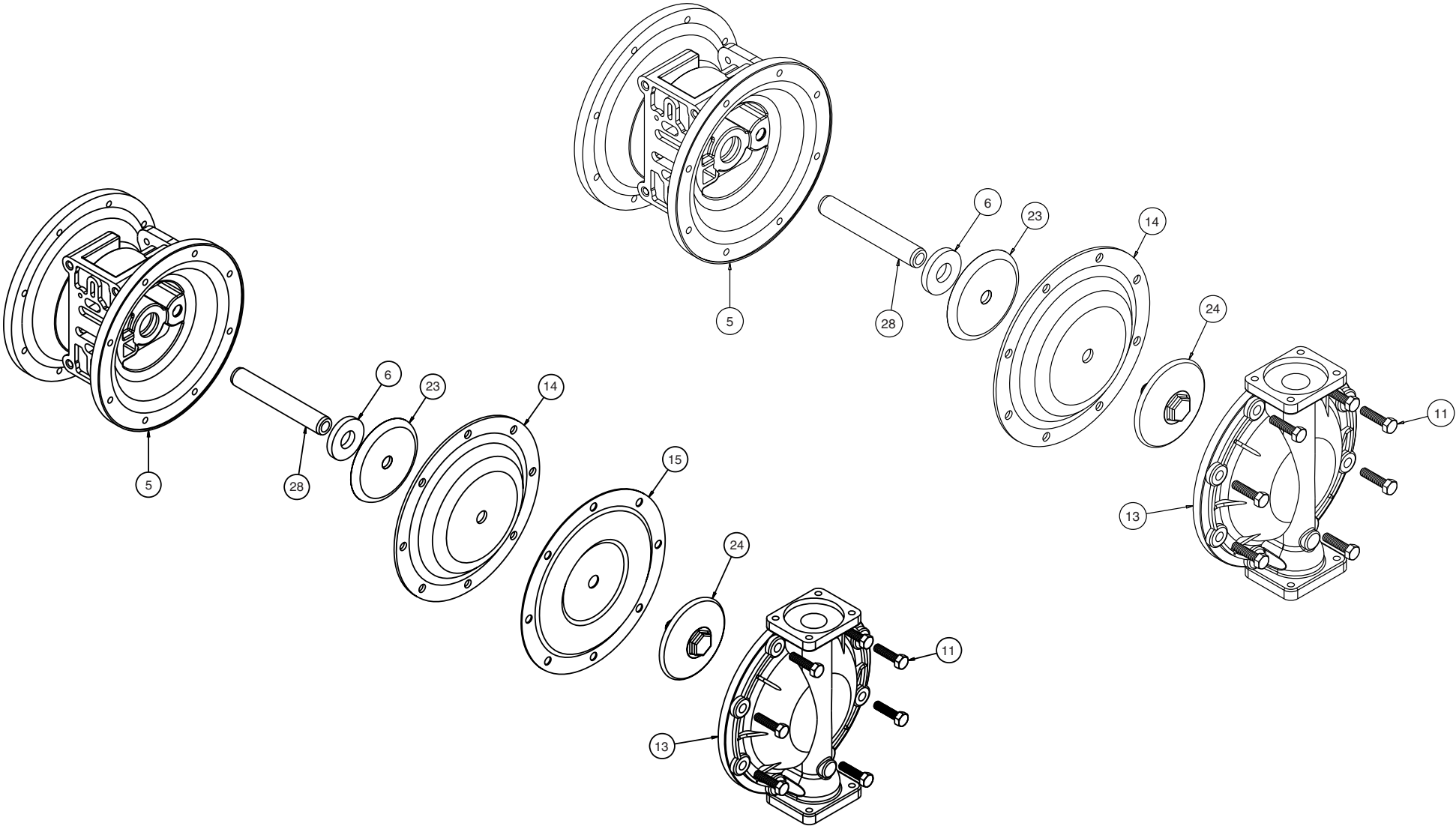

## DIAPHRAGM SERVICING

To service the diaphragms first shut off the suction, then shut off the discharge lines to the pump. Shut off the compressed air supply, bleed the pressure from the pump and disconnect the air supply line from the pump. Drain any remaining liquid from the pump.

**Step #1:** See the pump assembly drawing and the diaphragm servicing illustration.

Using a 1/2" wrench or socket, remove the 16 capscrews (item 9) that fasten the manifolds (items 19 & 20) to the outer chambers (item 13).

**Step #2:** Removing outer chambers.

Using a 1/2" wrench or socket, remove the 16 capscrews (item 11), that fasten the outer chambers (item 13), diaphragms (item 14) and intermediate (item 5) together.

**Step #3:** Removing the diaphragms and diaphragm plates.

Use a 7/8" wrench or six point socket to remove the outer diaphragm plate assemblies (item 24), diaphragms (item 14) and inner diaphragm plates (item 23) from the diaphragm rod (item 28) by turning counterclockwise. Inspect the diaphragm for cuts, punctures, abrasive wear or chemical attack. Replace the diaphragms if necessary. **DO NOT USE A WRENCH ON THE DIAPHRAGM ROD. FLAWS ON THE SURFACE MAY DAMAGE BEARINGS AND SEALS.**

**Step #4:** Assembling the diaphragm and diaphragm plates to the diaphragm rod.

Push the threaded stud of one outer diaphragm plate assembly through the center of one diaphragm and through one inner diaphragm plate. Install the diaphragm with the natural bulge facing away from the diaphragm rod and make sure the radius on the inner diaphragm plate is towards the diaphragm, as indicated on the diaphragm servicing illustration. Thread the assembly onto the diaphragm rod, leaving loose.

**Step #5:** Installing the diaphragm and rod assembly to the pump.

Make sure the bumper (item 6) is installed over the diaphragm rod. Insert rod into pump.

On the opposite side of the pump, pull the diaphragm rod out as far as possible. Make sure the second bumper is installed over the diaphragm rod.

Push the threaded stud of the other outer diaphragm plate assembly through the center of the other diaphragm and through the other inner diaphragm plate. Make sure the radius on the inner diaphragm plate is towards the diaphragm. Thread the assembly onto the diaphragm rod. Use a 7/8" wrench or socket to hold one outer diaphragm plate. Then, use a torque wrench to tighten the other outer diaphragm plate to the diaphragm rod to 350 in. lbs. (39.5 Newton meters).

Align one diaphragm with the intermediate and install the outer chamber to the pump using the 8 capscrews. Tighten the opposite diaphragm plate until the holes in the diaphragm align with the holes in the intermediate. Then, install the other outer chamber using the 8 capscrews.

**Step #6:** Reinstall the manifolds to the pump using the 16 capscrews.

The pump is now ready to be reinstalled, connected and returned to operation.

## OVERLAY DIAPHRAGM SERVICING

The overlay diaphragm (item 15) is designed to fit over the exterior of the standard diaphragm (item 14).

Follow the same procedures described for the standard diaphragm for removal and installation, except tighten the outer diaphragm plate assembly, diaphragms and inner diaphragm plate to the diaphragm rod to 350 in. lbs. (39.5 Newton meters).

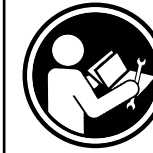

## ! IMPORTANT

*Read these instructions completely, before installation and start-up. It is the responsibility of the purchaser to retain this manual for reference. Failure to comply with the recommendations stated in this manual will damage the pump, and void factory warranty.*

## ACTUATOR PLUNGER SERVICING

To service the actuator plunger first shut off the compressed air supply, bleed the pressure from the pump, and disconnect the air supply line from the pump.

### Step #1: See PUMP ASSEMBLY DRAWING.

Using a 1/2" wrench or socket, remove the four capscrews (items 11). Remove the air inlet cap (item 8) and air inlet gasket (item 18). The pilot valve assembly (item 4) can now be removed.

### Step #2: Inspect the actuator plungers.

See ILLUSTRATION AT RIGHT.

The actuator plungers (items 25) can be reached through the pilot valve cavity in the intermediate assembly (item 5).

Remove the plungers (item 25) from the bushings (item 7) in each end of the cavity. Inspect the installed o-ring (items 22) for cuts and/or wear. Replace the o-rings if necessary. Apply a light coating of grease to each o-ring and re-install the plungers in to the bushings. Push the plungers in as far as they will go.

To remove the bushings (item 7), first remove the retaining rings (item 26) by using a flat screwdriver. **NOTE:** It is recommended that new retaining rings be installed.

**Step #3:** Re-install the pilot valve assembly into the intermediate assembly.

Be careful to align the ends of the stem between the plungers when inserting the stem of the pilot valve into the cavity of the intermediate.

Re-install the gasket (item 18), air inlet cap (item 8) and capscrews (item 11).

Connect the air supply to the pump. The pump is now ready for operation.

## ACTUATOR PLUNGER SERVICING

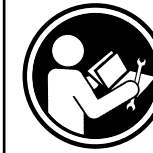
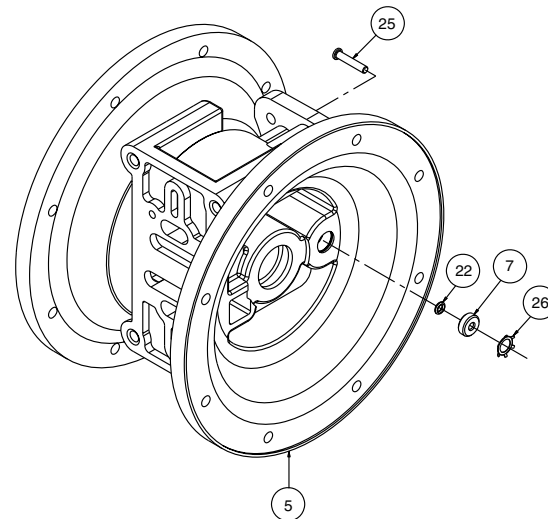

## IMPORTANT

*Read these instructions completely, before installation and start-up. It is the responsibility of the purchaser to retain this manual for reference. Failure to comply with the recommendations stated in this manual will damage the pump, and void factory warranty.*

## CHECK VALVE SERVICING

Before servicing the check valve components, first shut off the suction line and then the discharge line to the pump. Next, shut off the compressed air supply, bleed air pressure from the pump, and disconnect the air supply line from the pump. Drain any remaining fluid from the pump. The pump can now be removed for service.

To access the check valve components, remove the manifold (item 20 or item 19 not shown). Use a 1/2" wrench or socket to remove the fasteners. Once the manifold is removed, the check valve components can be seen.

Inspect the check balls (items 2) for wear, abrasion, or cuts on the spherical surface. The check valve seats (item 30) should be inspected for cuts, abrasive wear, or embedded material on the surfaces of both the external and internal chambers. The spherical surface of the check balls must seat flush to the surface of the check valve seats for the pump to operate to peak efficiency. Replace any worn or damaged parts as necessary.

Re-assemble the check valve components. The seat should fit into the counter bore of the outer chamber.

The pump can now be reassembled, reconnected and returned to operation.

## Check Valve Drawing

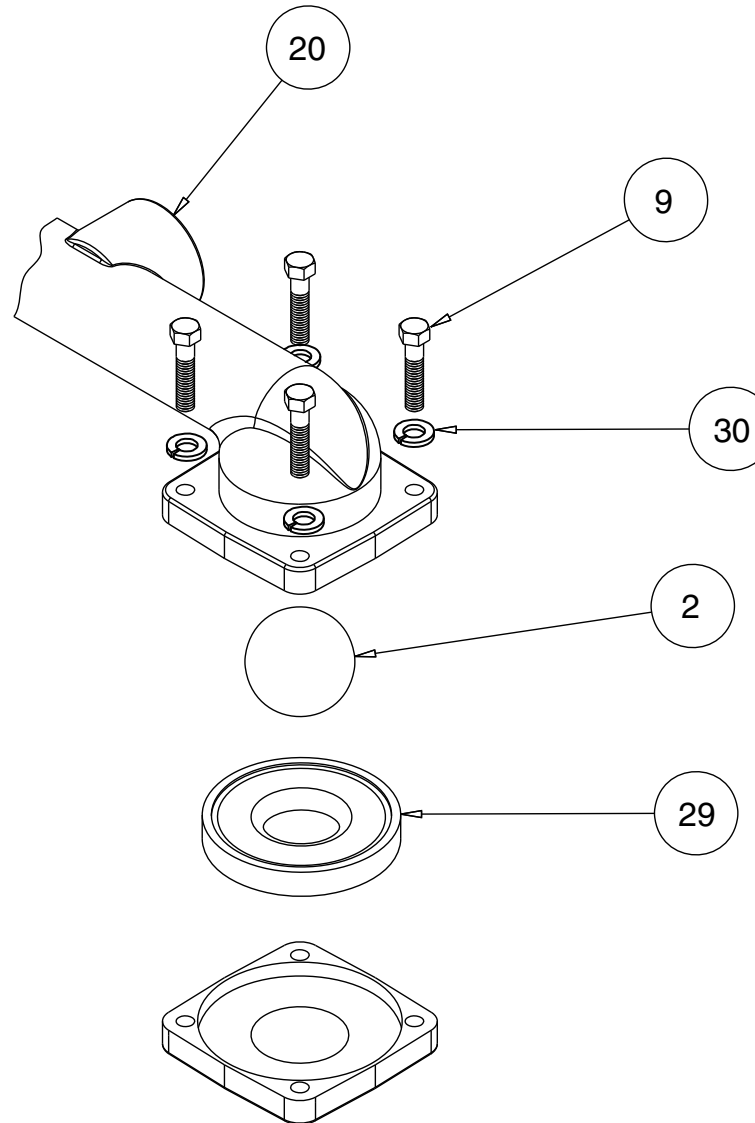

## PUMPING HAZARDOUS LIQUIDS

When a diaphragm fails, the pumped liquid or fumes enter the air end of the pump. Fumes are exhausted into the surrounding environment. When pumping hazardous or toxic materials, the exhaust air must be piped to an appropriate area for safe disposal. See illustration #1 at right.

This pump can be submerged if the pump materials of construction are compatible with the liquid being pumped. The air exhaust must be piped above the liquid level. See illustration #2 at right. Piping used for the air exhaust must not be smaller than 1" (2.54 cm) diameter. Reducing the pipe size will restrict air flow and reduce pump performance. When the pumped product source is at a higher level than the pump (flooded suction condition), pipe the exhaust higher than the product source to prevent siphoning spills. See illustration #3 at right.

## CONVERTING THE PUMP FOR PIPING THE EXHAUST AIR

The following steps are necessary to convert the pump to pipe the exhaust air away from the pump.

Remove the muffler (item 21). The air distribution valve (item 1) has 1" NPT threads for piped exhaust.

## IMPORTANT INSTALLATION

**NOTE:** The manufacturer recommends installing a flexible conductive hose or connection between the pump and any rigid plumbing. This reduces stresses on the molded threads of the air exhaust port. Failure to do so may result in damage to the air distribution valve body.

Any piping or hose connected to the pump's air exhaust port must be conductive and physically supported. Failure to support these connections could also result in damage to the air distribution valve body.

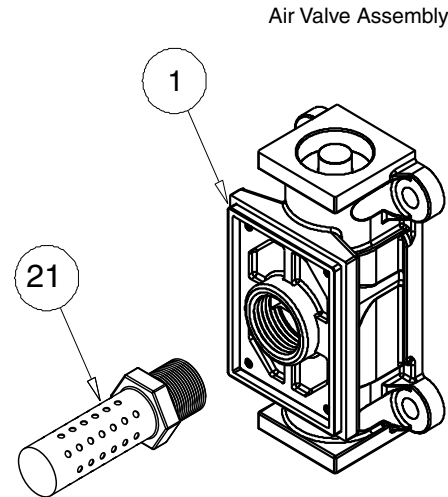

The pump comes equipped with a standard metal muffler

## CONVERTED EXHAUST ILLUSTRATION

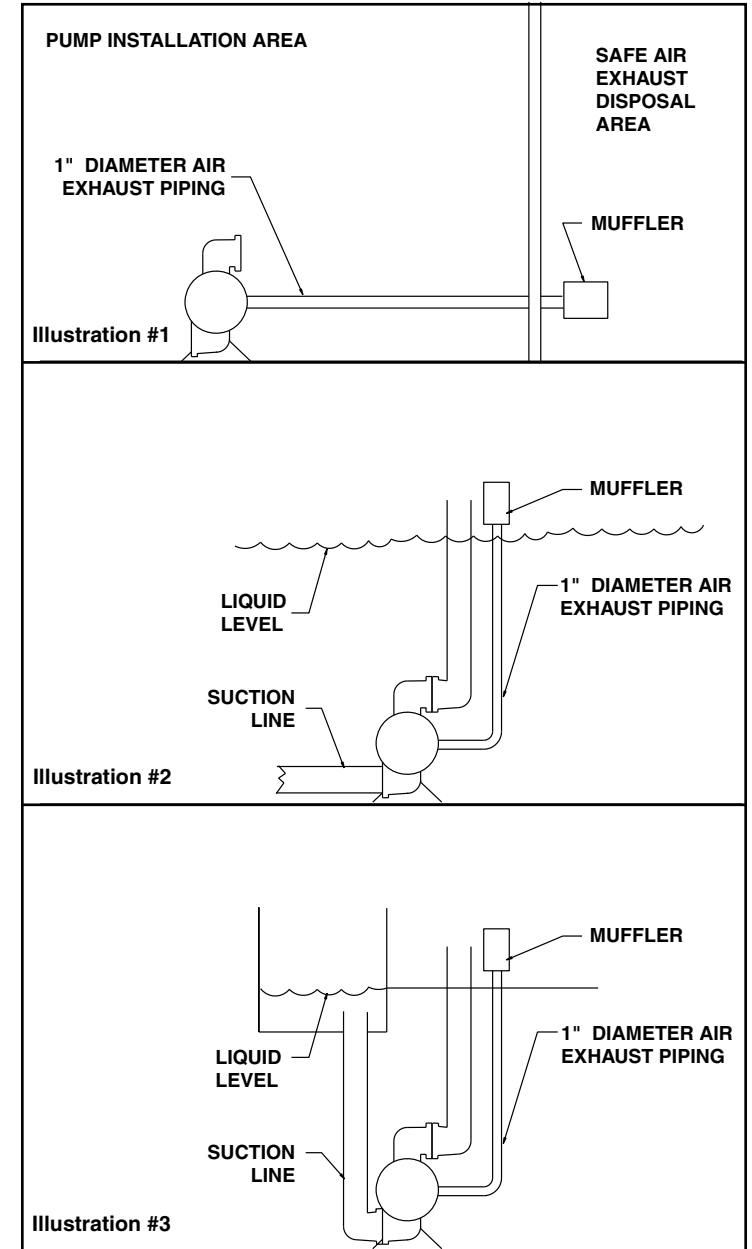

# Grounding The Pump

One eyelet is fastened to the pump hardware.

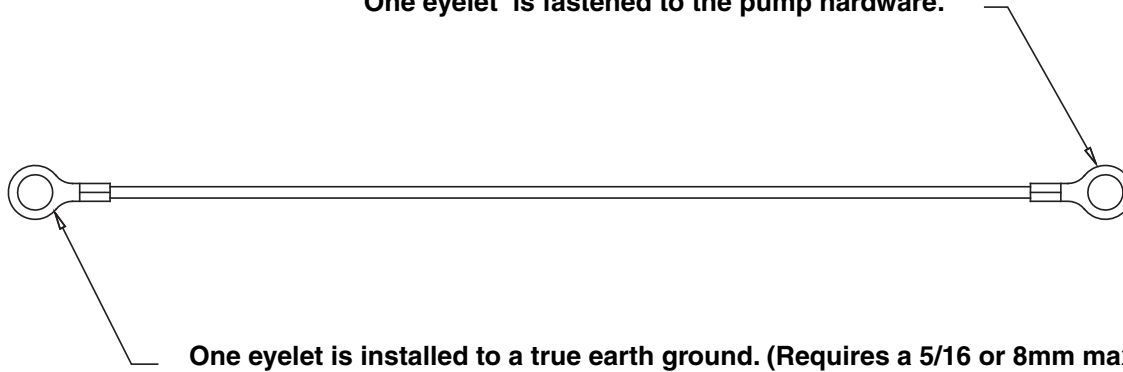

One eyelet is installed to a true earth ground. (Requires a 5/16 or 8mm maximum diameter bolt)

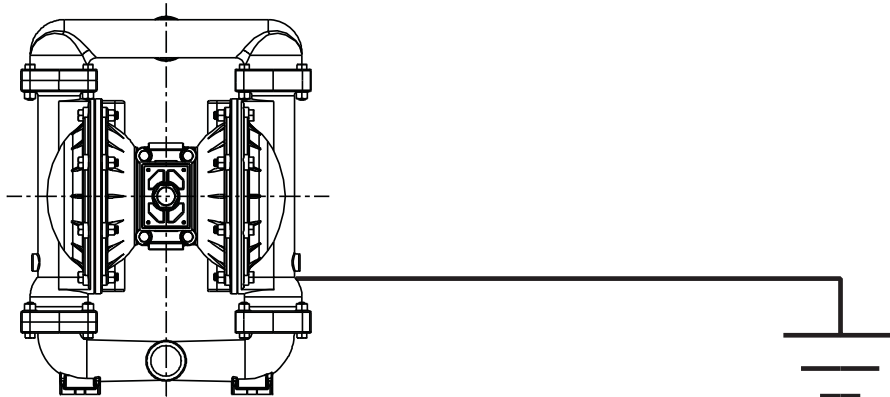

This 8 foot long (244 centimeters) Ground Strap (Item 32) is shipped with the eyelet end fastened to the pump hardware.

To reduce the risk of static electrical sparking, this pump must be grounded. Check the local electrical code for detailed grounding instruction and the type of equipment required, or in the absence of local codes, an industry or nationally recognized code having jurisdiction over specific installations and installation codes.

	<b>! WARNING</b>
	<i>Take action to prevent static sparking. Fire or explosion can result, especially when handling flammable liquids. The pump, piping, valves, containers or other miscellaneous equipment must be grounded.</i>

Declaration of Conformity

Declaration of Conformity

**WARREN  
RUPP®**

**IBEX**  
FLUID & METERING

## Declaration of Conformity

Warren Rupp, Inc., 800 North Main Street, Mansfield, Ohio, certifies that Air-Operated Double Diaphragm Pumps Series: HDB, HDF, M Non-Metallic, S Non-Metallic, M Metallic, S Metallic, T series, G series, U series, EH and SH High Pressure, W series, SMA and SPA Submersibles, and Tranquilizer Surge Suppressors comply with the European Community Directive 98/37/EC, Safety of Machinery. This product has used Harmonized Standard EN 809, Pumps and Pump Units for Liquids - Common Safety Requirements, to verify conformance.

David Roseberry  
Signature of authorized person

October 20, 2005  
Date of issue

David Roseberry  
Printed name of authorized person

Engineering Manager  
Title

Revision level A

August 6, 2008  
Date of revision



**WARREN  
RUPP®**

**IDEX**  
FLUID & METERING

# Declaration of Conformity ATEX 95

In accordance with Directive 94/9/EC, Annex VIII Equipment intended for use in potentially explosive environments.  
Technical File No. AX1 is stored at KEMA, Notified Body 0344, under document number 203040000.

**Manufacturer:**  
Warren Rupp, Inc.  
800 North Main Street  
P.O. Box 1568  
Mansfield, OH 44902 USA

**Applicable Standard:**  
94/9/EC  
EN13463-1  
For potentially explosive environments  
Group I, Category M2  
Group II, Category 2 GD



**Models:**

**Air-Operated Double Diaphragm Metallic Pumps Series:** EH, ET, G, HDB, HDF, M, MHP, MS, MP, SH, S, SA, SB, ST, T and U under SANDPIPER® and MARATHON® Brands

**Metal Surge Suppressors Series:** T and MSS under Tranquilizer® and MARATHON® Brands

**Air-Operated Double Diaphragm Nonmetallic Conductive Acetal Pump Models:** PB¼ and S05

**Air-Operated Double Diaphragm Nonmetallic Conductive Polypropylene Pump Models:** S05, S1F, S15, S20

**Air-Operated Double Diaphragm Nonmetallic Conductive PVDF Pump Models:** S05 and S1F

**SANDPIPER®**  
A WARREN RUPP PUMP BRAND

**MARATHON®**  
A WARREN RUPP PUMP BRAND

**DATE/APPROVAL/TITLE:**  
8 May 2003  
Rev G 20 January 2009

*David Roseberry*  
David Roseberry, Engineering Manager