

SERVICE & OPERATING MANUAL

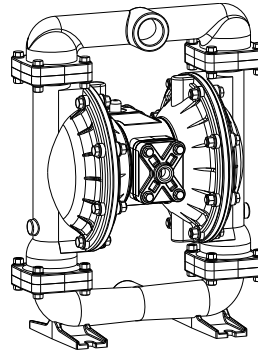

Model T15 Metallic FDA Compliant Design Level 1



U.S. Patent #
5,996,627
Other U.S. Patents
Applied for



II 2GD c T5

Table of Contents

Engineering Data and Temperature Limitations.....	1	Composite Repair Parts List.....	11
Explanation of Pump Nomenclature.....	2	Air Valve Drawing, Parts List, Service Instructions.....	12
Performance Curve.....	3	Pilot Valve Servicing, Assembly Drawing & Parts List.....	13
Dimensions.....	4	Diaphragm Service Drawing, with Overlay.....	14
Principle of Pump Operation.....	5	Diaphragm Service Drawing, Non-Overlay.....	14
Installation and Start-Up.....	5	Diaphragm Servicing.....	15
Air Supply.....	5	Overlay Diaphragm Servicing.....	15
Air Valve Lubrication.....	5	Actuator Plunger Servicing.....	16
Air Line Moisture.....	5	Check Valve Servicing.....	17
Air Inlet and Priming.....	5	Check Valve Drawing.....	17
Between Uses.....	5	Pumping Hazardous Liquids.....	18
Installation Guide.....	6	Converting Pump for Piping Exhaust Air.....	18
Troubleshooting.....	7	Converted Exhaust Illustration.....	18
Warranty.....	7	Grounding the Pump.....	19
Recycling.....	8	CE Declaration of Conformity.....	20
Important Safety Information.....	8		
Material Codes.....	9		
Composite Repair Parts Drawing.....	10		
Available Service and Conversion Kits.....	10		

**WARREN
RUPP®**

Quality System
ISO9001 Certified

Environmental
Management System
ISO14001 Certified

IDEX
FLUID & METERING

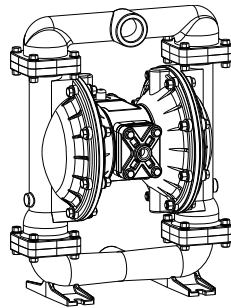

Air Inlet Side View

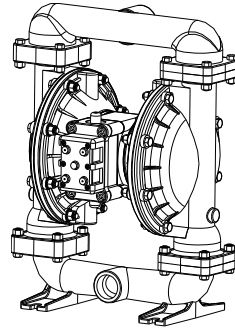

Air Exhaust Side View



II 2GD c T5

U.S. Patent #
5,996,627
Other U.S. Patents
Applied for



T15 Metallic

FDA Compliant Ball Valve Model Design Level 1

**Air-Powered
Double-Diaphragm Pump**

ENGINEERING, PERFORMANCE
& CONSTRUCTION DATA

INTAKE/DISCHARGE PIPE SIZE 2" Sanitary Clamp	CAPACITY 0 to 106 gallons per minute (0 to 401 liters per minute)	AIR VALVE No-lube, no-stall design	SOLIDS-HANDLING Up to .25 in. (6mm)	HEADS UP TO 125 psi or 289 ft. of water (8.6 Kg/cm ² or 86 meters)	DISPLACEMENT/STROKE .41 Gallon / 1.55 liter																	
<p>⚠ CAUTION! The maximum pump operating temperature limit is 190°F (88°C):</p> <table border="1"> <thead> <tr> <th rowspan="2">Materials</th> <th colspan="2">Temperature Limits</th> </tr> <tr> <th>Maximum</th> <th>Minimum</th> </tr> </thead> <tbody> <tr> <td>FDA Accepted White Nitrile: General purpose, oil-resistant. Shows good solvent, oil, water and hydraulic fluid resistance. Should not be used with highly polar solvents like acetone and MEK, ozone, chlorinated hydrocarbons and nitro hydrocarbons.</td> <td>190° F 88° C</td> <td>-10° F -23° C</td> </tr> <tr> <td>FDA Accepted Santoprene®: Injection molded thermoplastic elastomer with no fabric layer. Long mechanical flex life. Excellent abrasion resistance.</td> <td>275° F 135° C</td> <td>-40° F -40° C</td> </tr> <tr> <td>Virgin PTFE: Chemically inert, virtually impervious. Very few chemicals are known to react chemically with PTFE- molten alkali metals, turbulent liquid or gaseous fluorine and a few fluoro-chemicals such as chlorine trifluoride or oxygen difluoride which readily liberate free fluorine at elevated temperatures.</td> <td>350° F 177° C</td> <td>-40° F -40° C</td> </tr> <tr> <td>Polypropylene:</td> <td>180° F 82° C</td> <td>32° F 0° C</td> </tr> </tbody> </table>						Materials	Temperature Limits		Maximum	Minimum	FDA Accepted White Nitrile: General purpose, oil-resistant. Shows good solvent, oil, water and hydraulic fluid resistance. Should not be used with highly polar solvents like acetone and MEK, ozone, chlorinated hydrocarbons and nitro hydrocarbons.	190° F 88° C	-10° F -23° C	FDA Accepted Santoprene®: Injection molded thermoplastic elastomer with no fabric layer. Long mechanical flex life. Excellent abrasion resistance.	275° F 135° C	-40° F -40° C	Virgin PTFE: Chemically inert, virtually impervious. Very few chemicals are known to react chemically with PTFE- molten alkali metals, turbulent liquid or gaseous fluorine and a few fluoro-chemicals such as chlorine trifluoride or oxygen difluoride which readily liberate free fluorine at elevated temperatures.	350° F 177° C	-40° F -40° C	Polypropylene:	180° F 82° C	32° F 0° C
Materials	Temperature Limits																					
	Maximum	Minimum																				
FDA Accepted White Nitrile: General purpose, oil-resistant. Shows good solvent, oil, water and hydraulic fluid resistance. Should not be used with highly polar solvents like acetone and MEK, ozone, chlorinated hydrocarbons and nitro hydrocarbons.	190° F 88° C	-10° F -23° C																				
FDA Accepted Santoprene®: Injection molded thermoplastic elastomer with no fabric layer. Long mechanical flex life. Excellent abrasion resistance.	275° F 135° C	-40° F -40° C																				
Virgin PTFE: Chemically inert, virtually impervious. Very few chemicals are known to react chemically with PTFE- molten alkali metals, turbulent liquid or gaseous fluorine and a few fluoro-chemicals such as chlorine trifluoride or oxygen difluoride which readily liberate free fluorine at elevated temperatures.	350° F 177° C	-40° F -40° C																				
Polypropylene:	180° F 82° C	32° F 0° C																				

These pumps are designed to be powered only by compressed air.

Explanation of Pump Nomenclature

T15 Metallic · Design Level 1 · Ball Valve

MODEL	Pump Brand	Pump Size	Check Valve Type	Design Level	Wetted Material	Diaphragm/Check Valve Materials	Check Valve Seat	Non-Wetted Material Options	Porting Options	Pump Style	Pump Options	Shipping Kit Options	Weight lbs. (kg)
T15B1SDSWTS600.	T	15	B	1	S	D	S	W	T	S	6	00.	95 (43)
T15B1SSSWTS600.	T	15	B	1	S	S	S	W	T	S	6	00.	95 (43)
T15B1SDSSTS600.	T	15	B	1	S	D	S	S	T	S	6	00.	145 (66)
T15B1SSSSTS600.	T	15	B	1	S	S	S	S	T	S	6	00.	145 (66)

Pump Brand

T= FDA Compliant

Pump Size

15=1½"

Check Valve Type

B= Ball

Design Level

1= Design Level

Wetted Material

S= Stainless Steel

Diaphragm Check Valve Materials

D= FDA Santoprene/FDA Santoprene

S= PTFE-FDA Santoprene/PTFE

Check Valve Seat

S= Stainless Steel

T= PTFE

Non-Wetted Material Options

S= Stainless Steel w/Stainless Steel Hardware

W=White Epoxy Coated Aluminum w/Stainless Steel Hardware

Porting Options

T= 2" Sanitary Clamp Fitting

Pump Style

S= Standard

Pump Options



6= Metal Muffler



Kit Options

00.=None



Note: ATEX Compliant

Performance Curve, T15 Metallic Design Level 1

Performance based on the following: elastomer fitted pump, flooded suction, water at ambient conditions.
 The use of other materials and varying hydraulic conditions may result in deviations in excess of 5%.

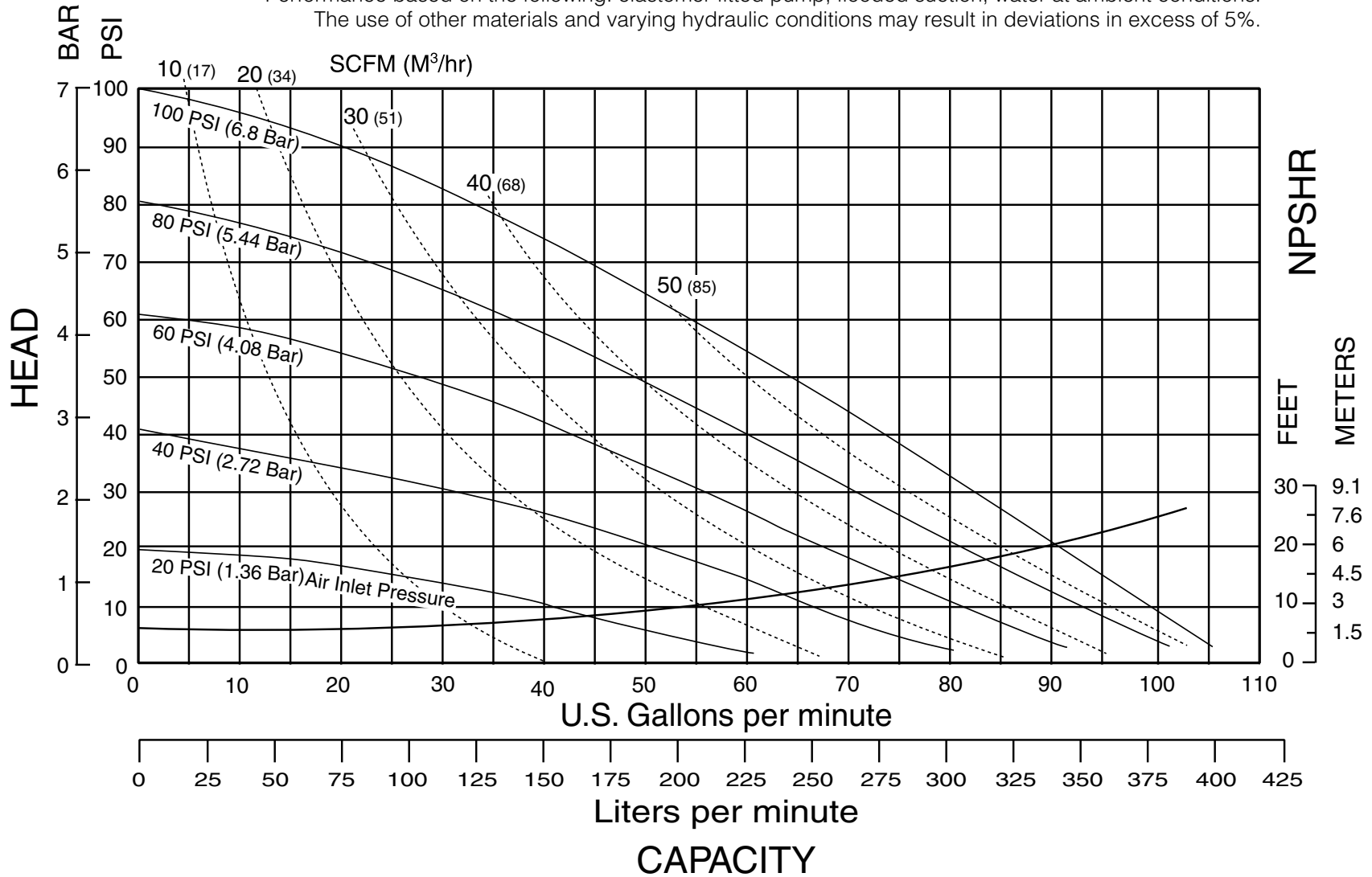

Dimensions: T15 Metallic

Dimensions in Inches
Dimensional Tolerance: $\pm 1/8$ "

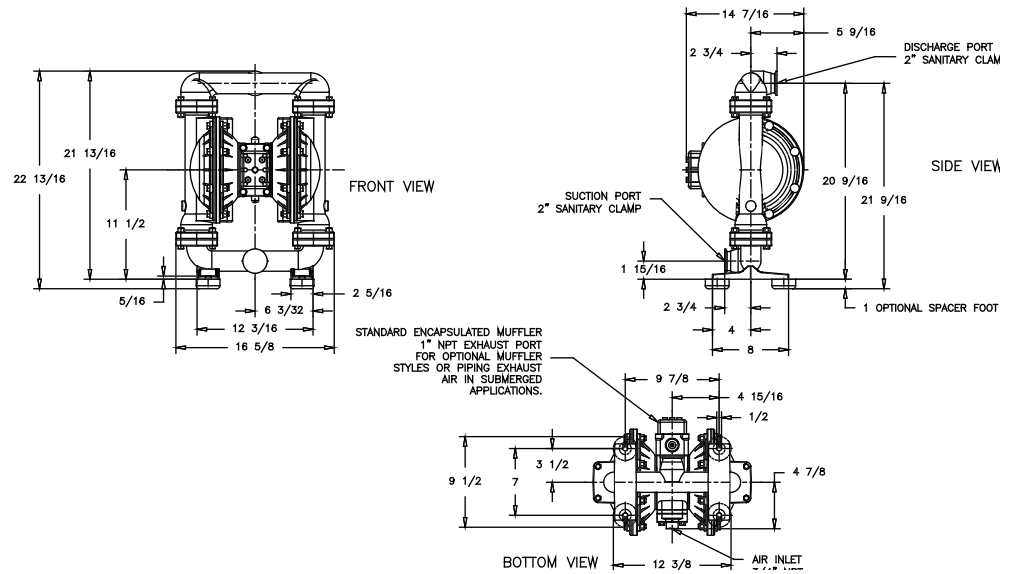

Dimensions in Millimeters
Dimensional Tolerance: ± 3 mm

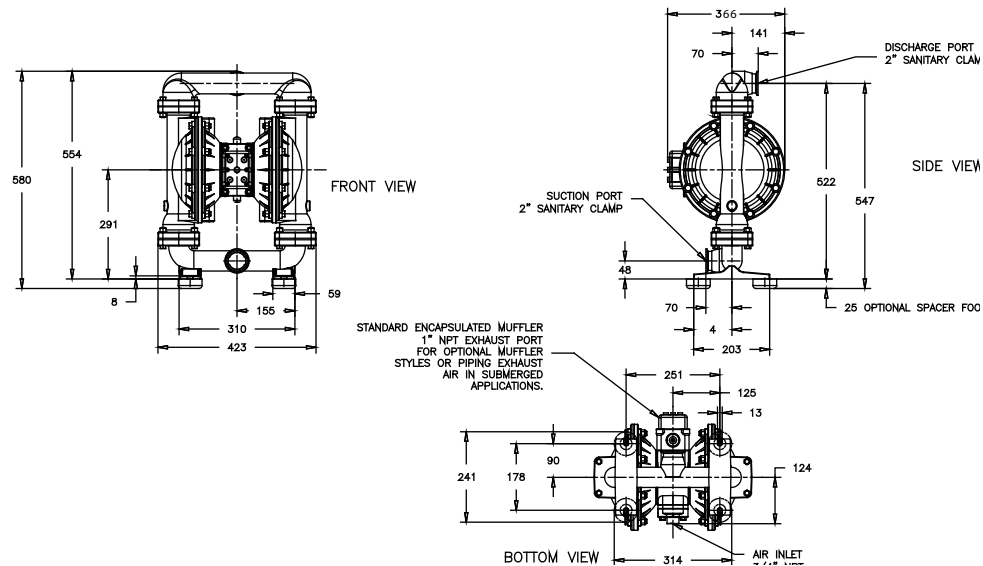

Dimension	A	B	C	D	E	F
Stainless Steel		20 3/8 518	1 31/32 50	3/8 10	11 3/8 289	21 21/32 550
Metal Muffler	14 1/2 368					

PRINCIPLE OF PUMP OPERATION

This ball type check valve pump is powered by compressed air and is a 1:1 ratio design. The inner side of one diaphragm chamber is alternately pressurized while simultaneously exhausting the other inner chamber. This causes the diaphragms, which are connected by a common rod secured by plates to the centers of the diaphragms, to move in a reciprocating action. (As one diaphragm performs the discharge stroke the other diaphragm is pulled to perform the suction stroke in the opposite chamber.) Air pressure is applied over the entire inner surface of the diaphragm while liquid is discharged from the opposite side of the diaphragm. The diaphragm operates in a balanced condition during the discharge stroke which allows the pump to be operated at discharge heads over 200 feet (61 meters) of water.

For maximum diaphragm life, keep the pump as close to the liquid being pumped as possible. Positive suction head in excess of 10 feet of liquid (3.048 meters) may require a back pressure regulating device to maximize diaphragm life.

Alternate pressurizing and exhausting of the diaphragm chamber is performed by an externally mounted, pilot operated, four way spool type air distribution valve. When the spool shifts to one end of the valve body, inlet pressure is applied to one diaphragm chamber and the other diaphragm chamber exhausts. When the spool

shifts to the opposite end of the valve body, the pressure to the chambers is reversed. The air distribution valve spool is moved by a internal pilot valve which alternately pressurizes one end of the air distribution valve spool while exhausting the other end. The pilot valve is shifted at each end of the diaphragm stroke when a actuator plunger is contacted by the diaphragm plate. This actuator plunger then pushes the end of the pilot valve spool into position to activate the air distribution valve.

The chambers are connected with manifolds with a suction and discharge check valve for each chamber, maintaining flow in one direction through the pump.

INSTALLATION AND START-UP

Locate the pump as close to the product being pumped as possible. Keep the suction line length and number of fittings to a minimum. Do not reduce the suction line diameter.

For installations of rigid piping, short sections of flexible hose should be installed between the pump and the piping. The flexible hose reduces vibration and strain to the pumping system. A surge suppressor is recommended to further reduce pulsation in flow.

AIR SUPPLY

Air supply pressure cannot exceed 125 psi (8.6 bar). Connect the pump air inlet to an air supply of sufficient capacity and pressure required for desired performance. When the air

supply line is solid piping, use a short length of flexible hose not less than 1/2" (13mm) in diameter between the pump and the piping to reduce strain to the piping. The weight of the air supply line, regulators and filters must be supported by some means other than the air inlet cap. Failure to provide support for the piping may result in damage to the pump. A pressure regulating valve should be installed to insure air supply pressure does not exceed recommended limits.

AIR VALVE LUBRICATION

The air distribution valve and the pilot valve are designed to operate WITHOUT lubrication. This is the preferred mode of operation. There may be instances of personal preference or poor quality air supplies when lubrication of the compressed air supply is required. The pump air system will operate with properly lubricated compressed air supply. Proper lubrication requires the use of an air line lubricator set to deliver one drop of SAE 10 non-detergent oil for every 20 SCFM (9.4 liters/sec.) of air the pump consumes at the point of operation. Consult the pump's published Performance Curve to determine this.

AIR LINE MOISTURE

Water in the compressed air supply can create problems such as icing or freezing of the exhaust air, causing the pump to cycle erratically or stop operating. Water in the air supply can be reduced by using a point-of-use air dryer to supplement the user's air

drying equipment. This device removes water from the compressed air supply and alleviates the icing or freezing problems.

AIR INLET AND PRIMING

To start the pump, open the air valve approximately 1/2" to 3/4" turn. After the pump primes, the air valve can be opened to increase air flow as desired. If opening the valve increases cycling rate, but does not increase the rate of flow, cavitation has occurred. The valve should be closed slightly to obtain the most efficient air flow to pump flow ratio.

BETWEEN USES

When the pump is used for materials that tend to settle out or solidify when not in motion, the pump should be flushed after each use to prevent damage. (Product remaining in the pump between uses could dry out or settle out. This could cause problems with the diaphragms and check valves at restart.) In freezing temperatures the pump must be completely drained between uses in all cases.

INSTALLATION GUIDE

Top Discharge Ball or Flap Valve Unit

Available Items

- ① Surge Suppressor
- ② Filter/Regulator
- ③ Air Dryer



CAUTION
The air exhaust should be piped to an area for safe disposition of the product being pumped, in the event of a diaphragm failure.

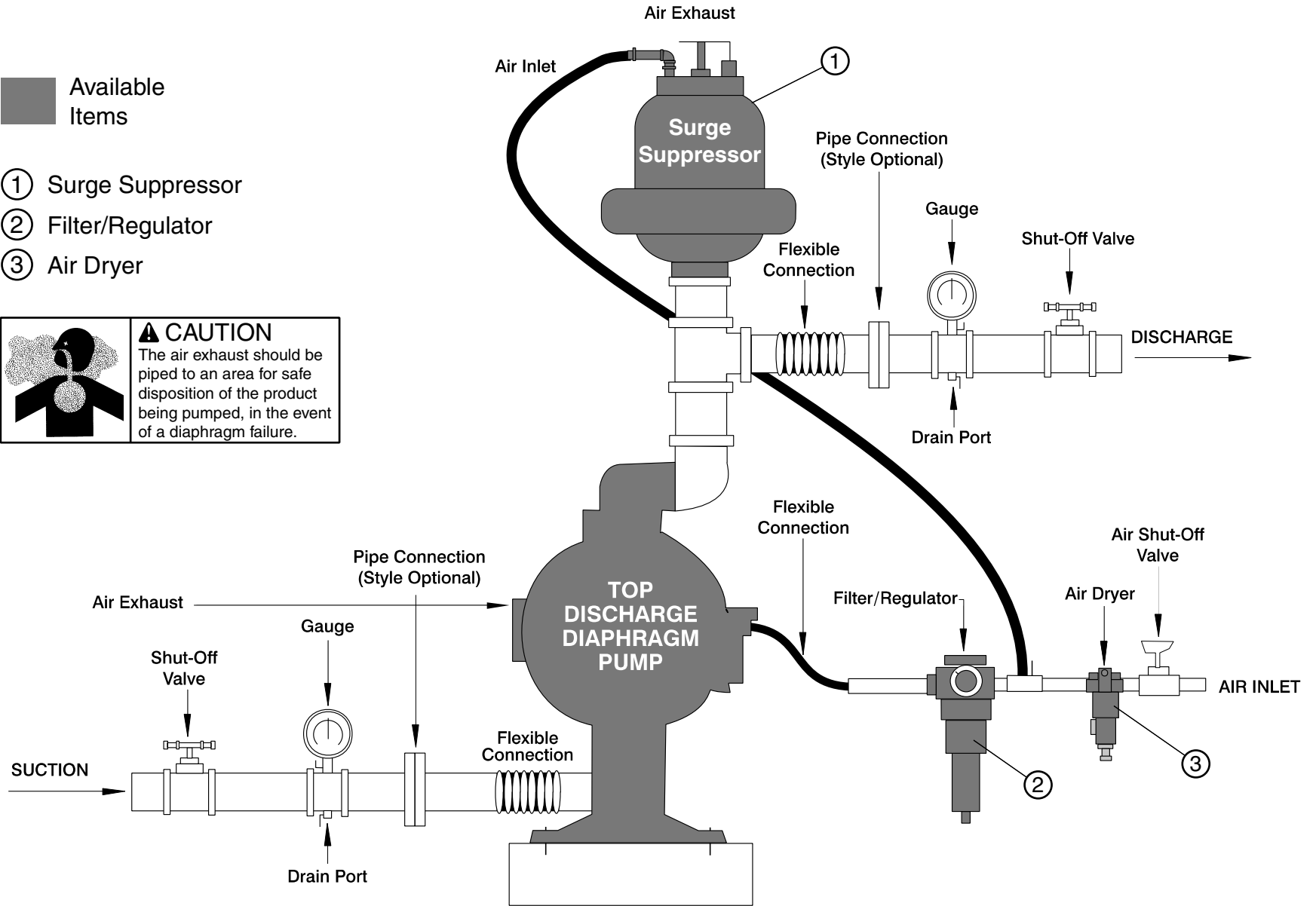

TROUBLESHOOTING

Possible Symptoms:

- Pump will not cycle.
- Pump cycles, but produces no flow.
- Pump cycles, but flow rate is unsatisfactory.
- Pump cycle seems unbalanced.
- Pump cycle seems to produce excessive vibration.

What to Check: Excessive suction lift in system.

Corrective Action: For lifts exceeding 20 feet (6 meters), filling the pumping chambers with liquid will prime the pump in most cases.

What to Check: Excessive flooded suction in system.

Corrective Action: For flooded conditions exceeding 10 feet (3 meters) of liquid, install a back pressure device.

What to Check: System head exceeds air supply pressure.

Corrective Action: Increase the inlet air pressure to the pump. Most diaphragm pumps are designed for 1:1 pressure ratio at zero flow.

What to Check: Air supply pressure or volume exceeds system head.

Corrective Action: Decrease inlet air pressure and volume to the pump as calculated on the published PERFORMANCE CURVE. Pump is cavitating the fluid by fast cycling.

What to Check: Undersized suction line.

Corrective Action: Meet or exceed pump connection recommendations shown on the DIMENSIONAL DRAWING.

What to Check: Restricted or undersized air line.

Corrective Action: Install a larger air line and connection. Refer to air inlet recommendations shown in your pump's SERVICE MANUAL.

What to Check: Check ESADS, the Externally Serviceable Air Distribution System of the pump.

Corrective Action: Disassemble and inspect the main air distribution valve, pilot valve and pilot valve actuators. Refer to the parts drawing and air valve section of the SERVICE MANUAL. Check for clogged discharge or closed valve before reassembly.

What to Check: Rigid pipe connections to pump.

Corrective Action: Install flexible connectors and a Surge Suppressor.

What to Check: Blocked air exhaust muffler.

Corrective Action: Remove muffler screen, clean or de-ice and reinstall. Refer to the Air Exhaust section of your pump SERVICE MANUAL.

What to Check: Pumped fluid in air exhaust muffler.

Corrective Action: Disassemble pump chambers. Inspect for diaphragm rupture or loose diaphragm plate assembly. Refer to the Diaphragm Replacement section of your pump SERVICE MANUAL.

What to Check: Suction side air leakage or air in product.

Corrective Action: Visually inspect all suction side gaskets and pipe connections.

What to Check: Obstructed check valve.

Corrective Action: Disassemble the wet end of the pump and manually dislodge obstruction in the check valve pocket. Refer to the Check Valve section of the pump SERVICE MANUAL for disassembly instructions.

What to Check: Worn or misaligned check valve or check valve seat.

Corrective Action: Inspect check valves and seats for wear and proper seating. Replace if necessary. Refer to Check Valve section of the pump SERVICE MANUAL for disassembly instructions.

What to Check: Blocked suction line.

Corrective Action: Remove or flush obstruction. Check and clear all suction screens and strainers.

What to Check: Blocked discharge line.

Corrective Action: Check for obstruction or closed discharge line valves.

What to Check: Blocked pumping chamber.

Corrective Action: Disassemble and inspect the wetted chambers of the pump. Remove or flush any obstructions. Refer to the pump SERVICE MANUAL for disassembly instructions.

What to Check: Entrained air or vapor lock in one or both pumping chambers.

Corrective Action: Purge chambers through tapped chamber vent plugs. PURGING THE CHAMBERS OF AIR CAN BE DANGEROUS! Any model with top-ported discharge will reduce or eliminate problems with entrained air.

If your pump continues to perform below your expectations, contact your local factory Technical Services Group for a service evaluation.

Recycling

Many components of Metallic AODD pumps are made of recyclable materials (see chart on page 10 for material specifications). We encourage pump users to recycle worn out parts and pumps whenever possible, after any hazardous pumped fluids are thoroughly flushed.

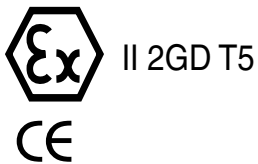

Pump complies with EN809 Pumping Directive, Directive 98/37/EC Safety of Machinery, and Directive 94/9/EC, EN13463-1 Equipment for use in Potentially Explosive Environments. The Technical File No. AX1 is stored at KEMA Notified Body 0344 under Document #203040000.

Important Safety Information



⚠ IMPORTANT

Read these safety warnings and instructions in this manual completely, before installation and start-up of the pump. It is the responsibility of the purchaser to retain this manual for reference. Failure to comply with the recommendations stated in this manual will damage the pump, and void factory warranty.



⚠ CAUTION

Before pump operation, inspect all gasketed fasteners for looseness caused by gasket creep. Retorque loose fasteners to prevent leakage. Follow recommended torques stated in this manual.



⚠ WARNING

Before maintenance or repair, shut off the compressed air line, bleed the pressure, and disconnect the air line from the pump. The discharge line may be pressurized and must be bled of its pressure.



⚠ WARNING

In the event of diaphragm rupture, pumped material may enter the air end of the pump, and be discharged into the atmosphere. If pumping a product which is hazardous or toxic, the air exhaust must be piped to an appropriate area for safe disposition.



⚠ WARNING

Take action to prevent static sparking. Fire or explosion can result, especially when handling flammable liquids. The pump, piping, valves, containers or other miscellaneous equipment must be grounded. (See page 19)



⚠ WARNING

This pump is pressurized internally with air pressure during operation. Always make certain that all bolting is in good condition and that all of the correct bolting is reinstalled during assembly.



⚠ WARNING

When used for toxic or aggressive fluids, the pump should always be flushed clean prior to disassembly.



⚠ WARNING

Before doing any maintenance on the pump, be certain all pressure is completely vented from the pump, suction, discharge, piping, and all other openings and connections. Be certain the air supply is locked out or made non-operational, so that it cannot be started while work is being done on the pump. Be certain that approved eye protection and protective clothing are worn all times in the vicinity of the pump. Failure to follow these recommendations may result in serious injury or death.

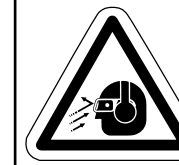

⚠ WARNING

Airborne particles and loud noise hazards. Wear ear and eye protection.

Material Codes

The Last 3 Digits of Part Number

000	Assembly, sub-assembly; and some purchased items	175	Die Cast Zinc	371	Phlithane (Tuftane)	602	Filled PTFE
010	Cast Iron	180	Copper Alloy	374	Carboxylated Nitrile	603	Blue Gylon
012	Powered Metal	305	Carbon Steel, Black Epoxy Coated	375	Fluorinated Nitrile	604	PTFE
015	Ductile Iron	306	Carbon Steel, Black PTFE Coated	378	High Density Polypropylene	606	PTFE
020	Ferritic Malleable Iron	307	Aluminum, Black Epoxy Coated	379	Conductive Nitrile	607	Envelon
025	Music Wire	308	Stainless Steel, Black PTFE Coated	405	Cellulose Fibre	608	Conductive PTFE
080	Carbon Steel, AISI B-1112	309	Aluminum, Black PTFE Coated	408	Cork and Neoprene	610	PTFE Encapsulated Silicon
100	Alloy 20	310	PVDF Coated	425	Compressed Fibre	611	PTFE Encapsulated FKM
110	Alloy Type 316 Stainless Steel	313	Aluminum, White Epoxy Coated	426	Blue Gard	632	Neoprene/Hytrel
111	Alloy Type 316 Stainless Steel (Electro Polished)	330	Zinc Plated Steel	440	Vegetable Fibre	633	FKM/PTFE
112	Alloy C	331	Chrome Plated Steel	465	Fibre	634	EPDM/PTFE
113	Alloy Type 316 Stainless Steel (Hand Polished)	332	Aluminum, Electroless Nickel Plated	500	Delrin 500	635	Neoprene/PTFE
114	303 Stainless Steel	333	Carbon Steel, Electroless Nickel Plated	501	Delrin 570	637	PTFE , FKM/PTFE
115	302/304 Stainless Steel	335	Galvanized Steel	502	Conductive Acetal, ESD-800	638	PTFE , Hytre/PTFE
117	440-C Stainless Steel (Martensitic)	336	Zinc Plated Yellow Brass	503	Conductive Acetal, Glass-Filled	639	Buna-N/TFE
120	416 Stainless Steel (Wrought Martensitic)	337	Silver Plated Steel	505	Acrylic Resin Plastic	643	Santoprene®/EPDM
123	410 Stainless Steel (Wrought Martensitic)	340	Nickel Plated	506	Delrin 150	644	Santoprene®/PTFE
148	Hardcoat Anodized Aluminum	342	Filled Nylon	520	Injection Molded PVDF Natural color	656	Santoprene Diaphragm and Check Balls/EPDM Seats
149	2024-T4 Aluminum	351	Food Grade Santoprene	540	Nylon	661	EPDM/Santoprene
150	6061-T6 Aluminum	353	Geolast; Color: Black	541	Nylon	666	FDA Nitrile Diaphragms PTFE Overlay, Balls, and Seals
151	6063-T6 Aluminum	354	Injection Molded #203-40 Santoprene- Duro 40D +/-5; Color: RED	542	Nylon	668	PTFE, FDA Santoprene/PTFE
152	2024-T4 Aluminum (2023-T351)	355	Thermal Plastic	544	Nylon Injection Molded		
154	Almag 35 Aluminum	356	Hytrel	550	Polyethylene		
155	356-T6 Aluminum	357	Injection Molded Polyurethane	551	Glass Filled Polypropylene		
156	356-T6 Aluminum	358	Urethane Rubber (Some Applications) (Compression Mold)	552	Unfilled Polypropylene		
157	Die Cast Aluminum Alloy #380	359	Urethane Rubber	553	Unfilled Polypropylene		
158	Aluminum Alloy SR-319	360	Buna-N Rubber. Color coded: RED	555	Polyvinyl Chloride		
159	Anodized Aluminum	361	Buna-N	556	Black Vinyl		
162	Brass, Yellow, Screw Machine Stock	363	FKM (Fluorel). Color coded: YELLOW	558	Conductive HDPE		
165	Cast Bronze, 85-5-5-5	364	E.P.D.M. Rubber. Color coded: BLUE	559	Glass Filled Conductive Polypropylene		
166	Bronze, SAE 660	365	Neoprene Rubber. Color coded: GREEN	570	Rulon II		
170	Bronze, Bearing Type, Oil Impregnated	366	Food Grade Nitrile	580	Ryton		
		368	Food Grade EPDM	590	Valox		
		370	Butyl Rubber. Color coded: BROWN	591	Nylatron G-S		
				592	Nylatron NSB		
				600	PTFE (virgin material)		
				601	PTFE (Bronze and moly filled)		

Delrin and Hytel are registered tradenames of E.I. DuPont.

Gylon is a registered tradename of Garlock, Inc.

Nylatron is a registered tradename of Polymer Corp.

Santoprene is a registered tradename of Monsanto Corp.

Rulon II is a registered tradename of Dixion Industries Corp.

Ryton is a registered tradename of Phillips Chemical Co.

Valox is a registered tradename of General Electric Co.

Composite Repair Parts Drawing

****Note:** Pumps equipped with these components are not ATEX compliant.

AVAILABLE SERVICE AND CONVERSION KITS

476-227-000 AIR END KIT Air Valve Assembly, Pilot Valve Assembly, Seals, Bumpers, Gaskets, Plunger and O-rings.

476-182-351 WET END KIT (T15)

FDA Santoprene Diaphragms, Balls, and PTFE Encapsulated Seals

476-182-668 WET END KIT (T15)

FDA Nitrile Diaphragms, PTFE Overlay, Balls, and PTFE Encapsulated Seals

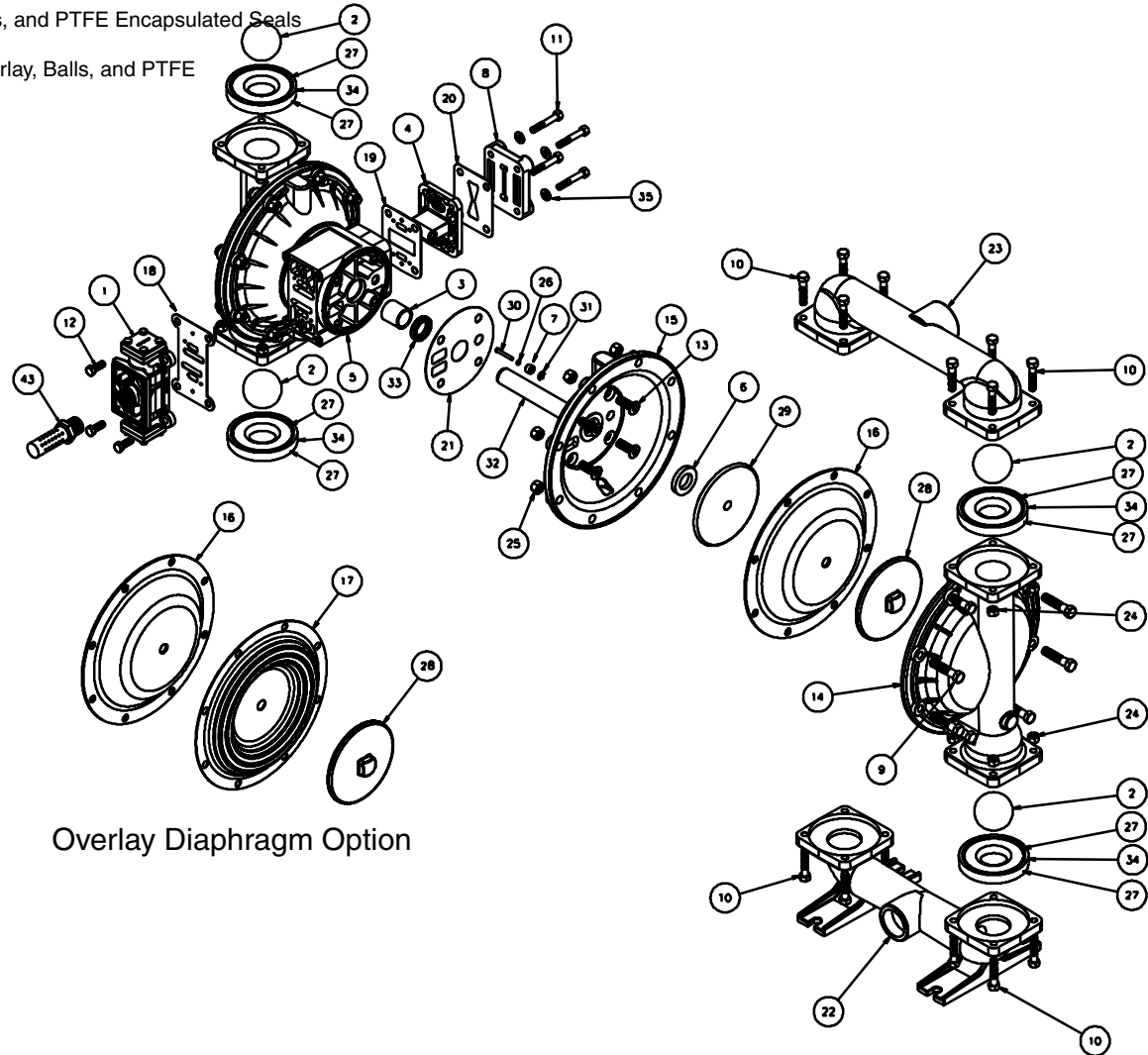

Composite Repair Parts List For T15

ITEM	PART NUMBER	DESCRIPTION	QTY	ITEM	PART NUMBER	DESCRIPTION	QTY
1	031-183-313	Air Valve Assembly	1	23	518-152-110TC	Manifold, Discharge	1
	031-179-000	Air Valve Assembly (ATEX compliant w/Cast Iron centers only)	1	24	545-005-115	Nut, Hex 3/8-16	16
2	050-005-351	Ball, Check	4	25	545-007-115	Nut, Hex 7/16-14	16
	050-010-600	Ball, Check	4	26	560-001-379	O-Ring	2
3	070-006-170	Bushing	2	27	560-084-611	Seal (O-Ring) (See item 34)	8
4	095-110-313	Pilot Valve Assembly	1		720-061-608	Seal (O-Ring) (See item 34)	8
	095-110-110	Pilot Valve Assembly (use w/Cast Iron centers only)	1	28	612-097-110	Plate, Outer Diaphragm Assembly	2
5	114-024-313	Intermediate Bracket	1	29	612-195-157	Plate, Inner Diaphragm	2
	114-024-110	Intermediate Bracket	1	30	620-020-115	Plunger, Actuator	2
6	132-035-360	Bumper, Diaphragm	2	31	675-042-115	Ring, Retaining	2
7	135-034-506	Bushing, Plunger	2	32	685-059-120	Rod, Diaphragm	1
8	165-118-313	Cap, Air Inlet Assembly	1	33	720-004-360	Seal, Diaphragm Rod	2
	165-118-110	Cap, Air Inlet Assembly	1	34	722-091-110	Seat, Check Ball (seals required see item 27)	4
9	170-060-115	Capscrew, Hex Hd 7/16-14 X 2.00	16	35	901-038-115	Washer, Flat 5/16	4
10	170-061-115	Capscrew, Hex Hd 3/8-16 X 1.75	16	36	901-048-115	Washer, Flat 3/8 (Stroke Indicator Only)	4
11	170-069-115	Capscrew, Hex Hd 5/16-18 X 1.75	4	43	530-033-000	Metal Muffler (for other muffler options see pg. 24)	1
12	170-006-115	Capscrew, Hex HD 3/8-16 X 1.00	4	Parts Not Shown (For Rubber Mounting Feet)			
	171-053-115	Capscrew, Soc Hd 3/8-16 X 2.50 (Stroke Indicator Only)	4		350-001-360	Foot, Rubber	4
13	171-059-115	Capscrew, Soc Hd 7/16-14 X 1.25	8		170-018-115	Capscrew, Hex HD	4
	171-011-115	Capscrew, Soc Hd 1/2-13 X 1.00 (Stainless Center)	8		545-005-115	Nut, Hex	4
14	196-169-110	Chamber, Outer	2		900-005-115	Washer, Lock	4
15	196-170-313	Chamber, Inner	2		901-005-115	Washer, Flat	8
	196-170-110	Chamber, Inner	2				
16	286-099-351	Diaphragm	2				
17	286-099-600	Diaphragm, Overlay	2				
18	360-093-360	Gasket, Air Valve	1				
19	360-103-360	Gasket, Pilot Valve	1				
20	360-104-379	Gasket, Air Inlet	1				
21	360-105-360	Gasket, Inner Chamber	2				
22	518-151-110TC	Manifold, Suction	1				

Air Valve Servicing, Assembly Drawing & Parts List

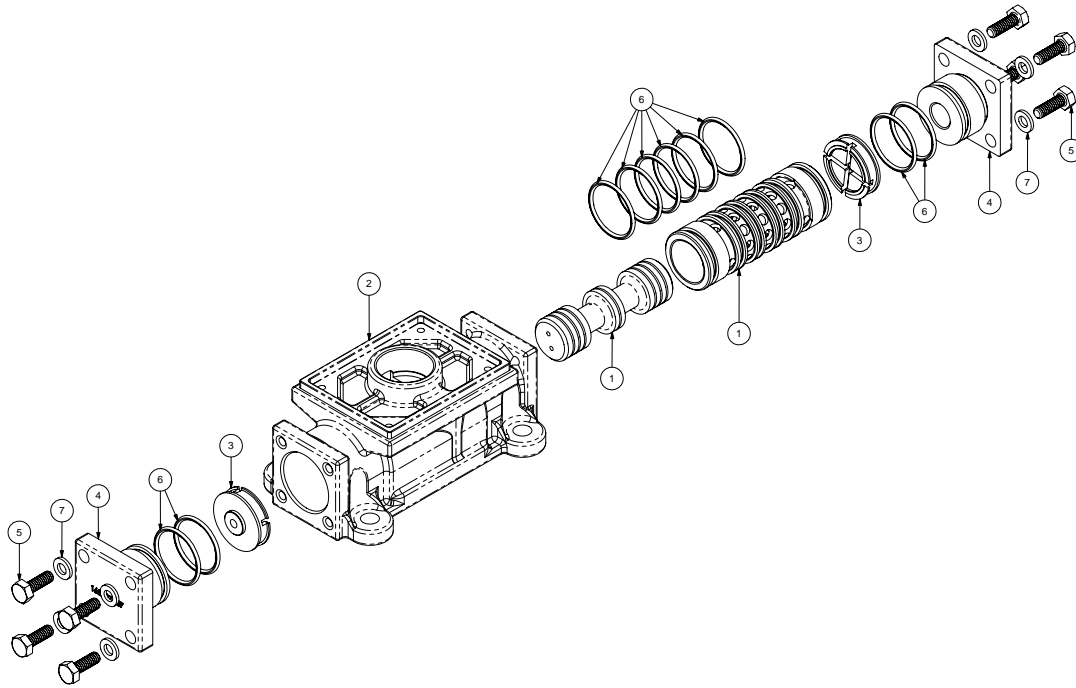

Air Valve Assembly Parts List (Use w/Aluminum centers only)

Item	Part Number	Description	Qty
1	031-183-313	Air Valve Assembly	1
1-A	095-109-313	Body, Air Valve	1
1-B	031-139-000	Sleeve and Spool Set	1
1-C	132-029-357	Bumper	2
1-D	560-020-360	O-Ring	10
1-E	165-127-313	Cap, End	2
1-F	170-032-115	Hex Head Capscrew 1/4-20 x .75	8
1-G	901-037-115	Flat Washer	8

Air Valve Assembly Parts List (Use w/Stainless Steel centers only)

Item	Part Number	Description	Qty
1	031-179-000	Air Valve Assembly	1
1-A	095-109-110	Body, Air Valve	1
1-B	031-139-000	Sleeve and Spool Set	1
1-C	132-029-357	Bumper	2
1-D	560-020-360	O-Ring	10
1-E	165-127-110	Cap, End	2
1-F	170-032-115	Hex Head Capscrew 1/4-20 x .75	8

AIR DISTRIBUTION VALVE SERVICING

To service the air valve first shut off the compressed air, bleed pressure from the pump, and disconnect the air supply line from the pump.

Step #1: See COMPOSITE REPAIR PARTS DRAWING.

Using a 9/16" wrench or socket, remove the four hex capscrews (items 12). Remove the air valve assembly from the pump.

Remove and inspect gasket (item 18) for cracks or damage. Replace gasket if needed.

Step #2: Disassembly of the air valve.

Using a 7/16" wrench or socket, remove the eight hex capscrews (items 1-F) that fasten the end caps to the valve body.

Next remove the two end caps (items 1-E). Inspect the two o-rings (items 1-D) on each end cap for damage or wear. Replace the o-rings as needed.

Remove the bumpers (items 1-C). Inspect the bumpers for damage or wear. Replace the bumpers as needed.

Remove the spool (part of item 1-B) from the sleeve. Be careful not to scratch or damage the outer diameter of the spool. Wipe spool with a soft cloth and inspect for scratches or wear.

Inspect the inner diameter of the sleeve (part of item 1-B) for dirt, scratches, or other contaminants. Remove the sleeve if needed and replace with a new sleeve and spool set (item 1-B).

Step #3: Reassembly of the air valve.

Install one bumper (item 1-C) and one end cap (item 1-E), with two o-rings (items 1-D), and fasten with four hex capscrews (items 1-F) to the valve body (item 1-A).

Remove the new sleeve and spool set (item 1-B) from the plastic bag. Carefully remove the spool from the sleeve. Install the six o-rings (item 1-D) into the six grooves on the sleeve. Apply a light coating of grease to the o-rings before installing the sleeve into the valve body (item 1-A), align the slots in the sleeve with the slots in the valve body. Insert the spool into the sleeve. Be careful not to scratch or damage the spool during installation. Carefully insert the sleeve into the bumper and end cap

(with o-rings) and fasten with the remaining hex capscrews.

Fasten the air valve assembly (item 1) and gasket to the pump. Connect the compressed air line to the pump. The pump is now ready for operation.



IMPORTANT

Read these instructions completely, before installation and start-up. It is the responsibility of the purchaser to retain

this manual for reference. Failure to comply with the recommendations stated in this manual will damage the pump, and void factory warranty.

Pilot Valve Servicing, Assembly Drawing & Parts List

PILOT VALVE ASSEMBLY PARTS LIST

ITEM	PART NUMBER	DESCRIPTION	QTY
4	095-110-313	Pilot Valve Assembly	1
4-A	095-095-313	Valve Body	1
4-B	755-052-000	Sleeve (With O-rings)	1
4-C	560-033-360	O-ring (Sleeve)	6
4-D	775-055-000	Spool (With O-rings)	1
4-E	560-023-360	O-ring (Spool)	3
4-F	675-037-080	Retaining Ring	1

FOR PUMPS WITH STAINLESS STEEL CENTER SECTION

ITEM	PART NUMBER	DESCRIPTION	QTY
4	095-110-110	Pilot Valve Assembly	1
4-A	095-095-110	Valve Body	1

(includes all other items used on 095-110-313)

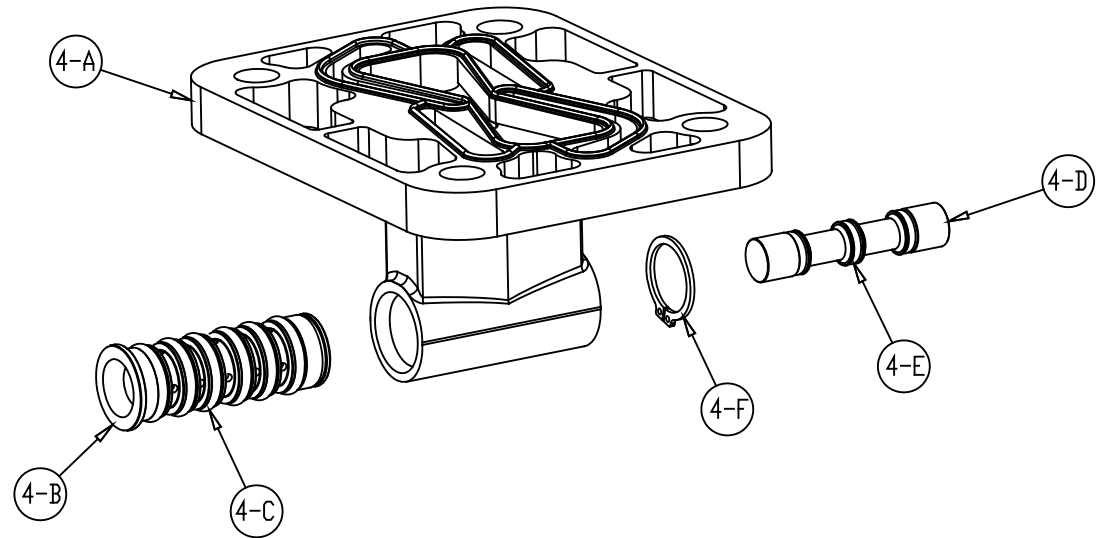

PILOT VALVE SERVICING

To service the pilot valve first shut off the compressed air supply, bleed the pressure from the pump, and disconnect the air supply line from the pump.

STEP #1: See pump assembly drawing.

Using a 1/2" wrench or socket, remove the four capscrews (item 11). Remove the air inlet cap (item 8) and air inlet gasket (item 20). The pilot valve assembly (item 4) can now be removed

for inspection and service.

STEP #2: Disassembly of the pilot valve.

Remove the pilot valve spool (item 4-D). Wipe clean and inspect spool and o-rings for dirt, cuts or wear. Replace the o-rings and spool if necessary.

Remove the retaining ring (item 4-F) from the end of the sleeve (item 4-B) and remove the sleeve from the valve body (item 4-A). Wipe clean and inspect sleeve and o-rings for dirt, cuts or wear. Replace the o-rings and sleeve if necessary.

STEP #3: Re-assembly of the pilot valve.

Generously lubricate outside diameter of the sleeve and o-rings. Then carefully insert sleeve into valve body. Take CAUTION when inserting sleeve, not to shear any o-rings. Install retaining ring to sleeve. Generously lubricate outside diameter of spool and o-rings. Then carefully insert spool into sleeve. Take CAUTION when inserting spool, not to shear any o-rings. Use BP-LS-EP-2 multipurpose grease, or equivalent.

STEP #4: Re-install the pilot valve assembly into the intermediate.

Be careful to align the ends of the pilot valve stem between the plunger pins when inserting the pilot valve into the cavity of the intermediate.

Re-install the gasket, air inlet cap and capscrews. Connect the air supply to the pump. The pump is now ready for operation.

DIAPHRAGM SERVICING

To service the diaphragms first shut off the suction, then shut off the discharge lines to the pump. Shut off the compressed air supply, bleed the pressure from the pump and disconnect the air supply line from the pump. Drain any remaining liquid from the pump.

Step #1: See the pump assembly drawing and the diaphragm servicing illustration.

Using a 1/2" wrench or socket, remove the 16 capscrews (item 9) that fasten the manifolds (items 22 & 23) to the outer chambers (item 14).

Step #2: Removing outer chambers.

Using a 1/2" wrench or socket, remove the 16 capscrews (item 9), that fasten the outer chambers (item 13), diaphragms (item 14) and intermediate (item 5) together.

Step #3: Removing the diaphragms and diaphragm plates.

Use a 7/8" wrench or six point socket to remove the outer diaphragm plate assemblies, diaphragms (item 16) and inner diaphragm plates (item 29) from the diaphragm rod (item 32) by turning counterclockwise. Inspect the diaphragm for cuts, punctures, abrasive wear or chemical attack. Replace the diaphragms if necessary. **DO NOT USE A WRENCH ON THE DIAPHRAGM ROD. FLAWS ON THE SURFACE MAY DAMAGE BEARINGS AND SEALS.**

Step #4: Assembling the diaphragm and diaphragm plates to the diaphragm rod.

Push the threaded stud of one outer diaphragm plate assembly through the center of one diaphragm and through one inner diaphragm plate. Install the diaphragm with the natural bulge facing away from the diaphragm rod and make sure the radius on the inner diaphragm plate is towards the diaphragm, as indicated on the diaphragm servicing illustration. Thread the assembly onto the diaphragm rod, leaving loose.

Step #5: Installing the diaphragm and rod assembly to the pump.

Make sure the bumper (item 6) is installed over the diaphragm rod. Insert rod into pump.

On the opposite side of the pump, pull the diaphragm rod out as far as possible. Make sure the second bumper is installed over the diaphragm rod.

Push the threaded stud of the other outer diaphragm plate assembly through the center of the other diaphragm and through the other inner diaphragm plate. Make sure the radius on the inner diaphragm plate is towards the diaphragm. Thread the assembly onto the diaphragm rod. Use a 7/8" wrench or socket to hold one outer diaphragm plate. Then, use a torque wrench to tighten the other outer diaphragm plate to the diaphragm rod to 500 in. lbs. (56.5 Newton meters).

Align one diaphragm with the intermediate and install the outer chamber to the pump using the 8 capscrews. Tighten the opposite diaphragm plate until the holes in the diaphragm align with the holes in the intermediate. Then, install the other outer chamber using the 8 capscrews.

Step #6: Reinstall the manifolds to the pump using the 16 capscrews.

The pump is now ready to be reinstalled, connected and returned to operation.

OVERLAY DIAPHRAGM SERVICING

The overlay diaphragm (item 17) is designed to fit over the exterior of the standard diaphragm (item 16).

Follow the same procedures described for the standard diaphragm for removal and installation, except tighten the outer diaphragm plate assembly, diaphragms and inner diaphragm plate to the diaphragm rod to 500 in. lbs. (56.5 Newton meters).

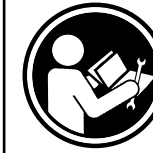

! IMPORTANT

Read these instructions completely, before installation and start-up. It is the responsibility of the purchaser to retain this manual for reference. Failure to comply with the recommendations stated in this manual will damage the pump, and void factory warranty.

ACTUATOR PLUNGER SERVICING

To service the actuator plunger first shut off the compressed air supply, bleed the pressure from the pump, and disconnect the air supply line from the pump.

Step #1: See PUMP ASSEMBLY DRAWING.

Using a 1/2" wrench or socket, remove the four capscrews (items 11). Remove the air inlet cap (item 8) and air inlet gasket (item 18). The pilot valve assembly (item 4) can now be removed.

Step #2: Inspect the actuator plungers.

See ILLUSTRATION AT RIGHT.

The actuator plungers (items 30) can be reached through the pilot valve cavity in the intermediate assembly (item 5).

Remove the plungers (item 30) from the bushings (item 7) in each end of the cavity. Inspect the installed o-ring (items 26) for cuts and/or wear. Replace the o-rings if necessary. Apply a light coating of grease to each o-ring and re-install the plungers in to the bushings. Push the plungers in as far as they will go.

To remove the bushings (item 7), first remove the retaining rings (item 31) by using a flat screwdriver. **NOTE:** It is recommended that new retaining rings be installed.

Step #3: Re-install the pilot valve assembly into the intermediate assembly.

Be careful to align the ends of the stem between the plungers when inserting the stem of the pilot valve into the cavity of the intermediate.

Re-install the gasket (item 18), air inlet cap (item 8) and capscrews (item 11).

Connect the air supply to the pump. The pump is now ready for operation.

ACTUATOR PLUNGER SERVICING

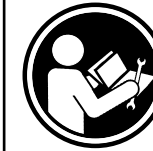
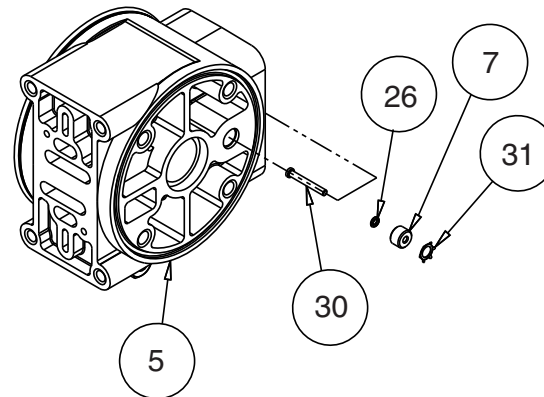

! IMPORTANT

Read these instructions completely, before installation and start-up. It is the responsibility of the purchaser to retain this manual for reference. Failure to comply with the recommendations stated in this manual will damage the pump, and void factory warranty.

CHECK VALVE SERVICING

Before servicing the check valve components, first shut off the suction line and then the discharge line to the pump. Next, shut off the compressed air supply, bleed air pressure from the pump, and disconnect the air supply line from the pump. Drain any remaining fluid from the pump. The pump can now be removed for service.

To access the check valve components, remove the manifold (item 23 or item 22 not shown). Use a 1/2" wrench or socket to remove the fasteners. Once the manifold is removed, the check valve components can be seen.

Inspect the check balls (items 2) for wear, abrasion, or cuts on the spherical surface. The check valve seats (item 34) should be inspected for cuts, abrasive wear, or embedded material on the surfaces of both the external and internal chambers. The spherical surface of the check balls must seat flush to the surface of the check valve seats for the pump to operate to peak efficiency. Replace any worn or damaged parts as necessary.

Re-assemble the check valve components. The seat should fit into the counter bore of the outer chamber.

The pump can now be reassembled, reconnected and returned to operation.

METALLIC SEATS

Two o-rings (item 27) are required for metallic seats.

Check Valve Drawing

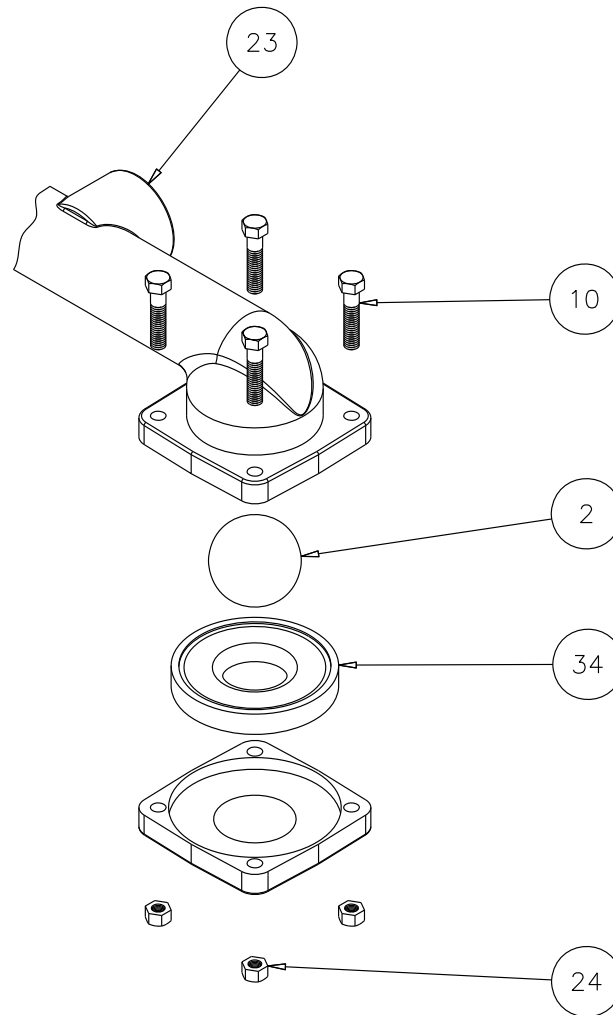

PUMPING HAZARDOUS LIQUIDS

When a diaphragm fails, the pumped liquid or fumes enter the air end of the pump. Fumes are exhausted into the surrounding environment. When pumping hazardous or toxic materials, the exhaust air must be piped to an appropriate area for safe disposal. See illustration #1 at right.

This pump can be submerged if the pump materials of construction are compatible with the liquid being pumped. The air exhaust must be piped above the liquid level. See illustration #2 at right. Piping used for the air exhaust must not be smaller than 1" (2.54 cm) diameter. Reducing the pipe size will restrict air flow and reduce pump performance. When the pumped product source is at a higher level than the pump (flooded suction condition), pipe the exhaust higher than the product source to prevent siphoning spills. See illustration #3 at right.

CONVERTING THE PUMP FOR PIPING THE EXHAUST AIR

The following steps are necessary to convert the pump to pipe the exhaust air away from the pump.

Remove the muffler (item 43). The air distribution valve (item 1) has 1" NPT threads for piped exhaust.

IMPORTANT INSTALLATION

NOTE: The manufacturer recommends installing a flexible conductive hose or connection between the pump and any rigid plumbing. This reduces stresses on the molded threads of the air exhaust port. Failure to do so may result in damage to the air distribution valve body.

Any piping or hose connected to the pump's air exhaust port must be conductive and physically supported. Failure to support these connections could also result in damage to the air distribution valve body.

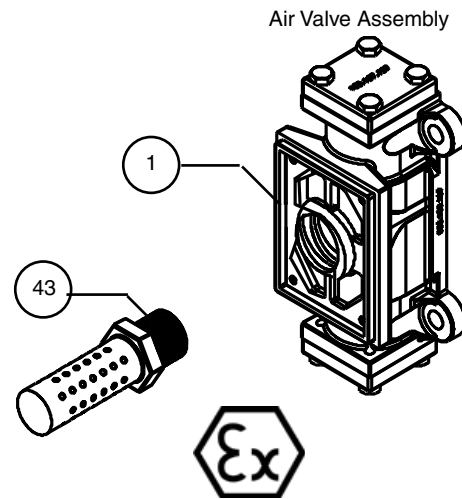

On ATEX compliant units the pump comes equipped with a standard metal muffler

CONVERTED EXHAUST ILLUSTRATION

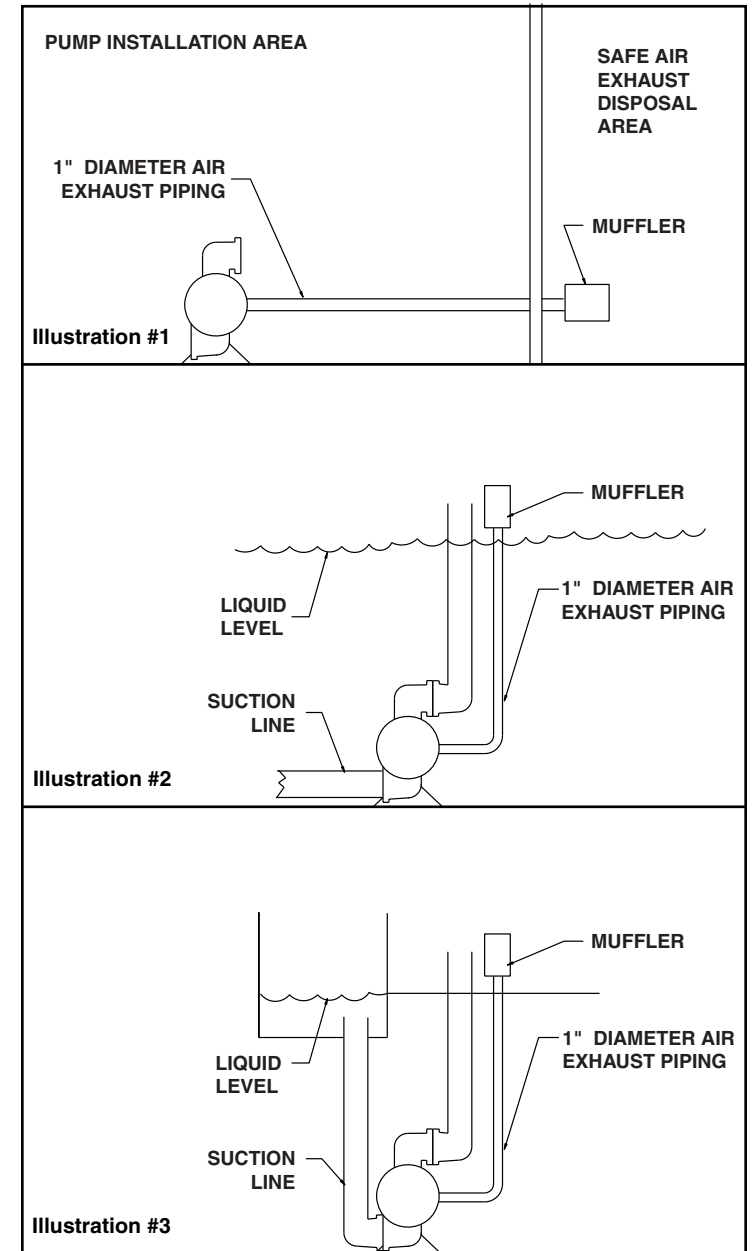

Grounding The Pump

To be fully groundable, the pumps must be ATEX Compliant. Refer to pump data sheet for ordering.

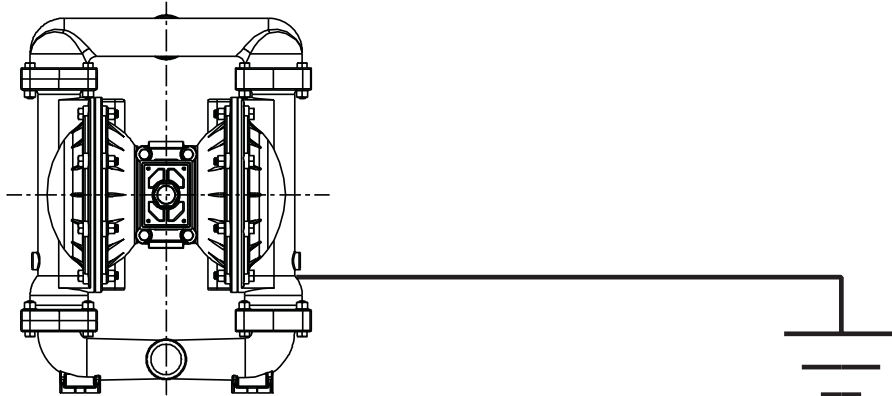
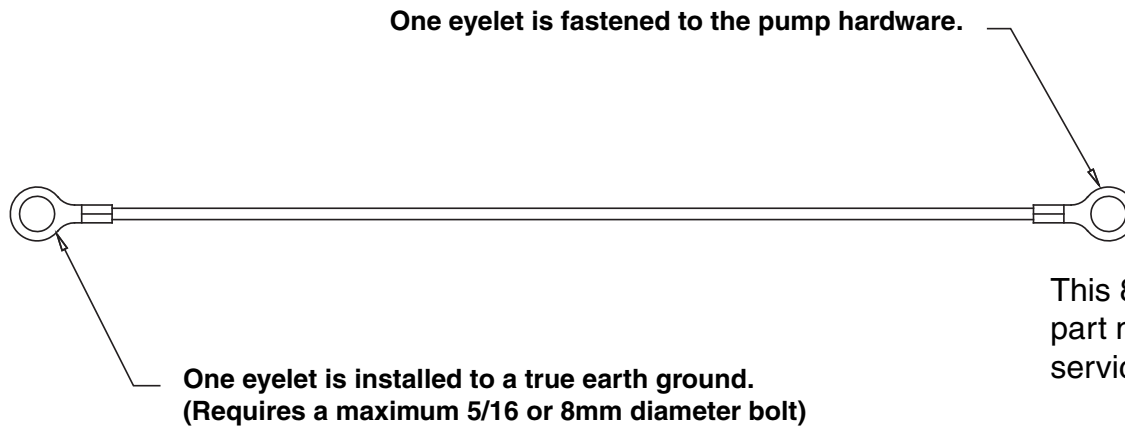

	! WARNING
	<i>Take action to prevent static sparking. Fire or explosion can result, especially when handling flammable liquids. The pump, piping, valves, containers or other miscellaneous equipment must be grounded.</i>

Declaration of Conformity



**WARREN
RUPP®**

IDEX
FLUID & METERING

Declaration of Conformity

Warren Rupp, Inc., 800 North Main Street, Mansfield, Ohio, certifies that Air-Operated Double Diaphragm Pumps Series: HDB, HDF, M Non-Metallic, S Non-Metallic, M Metallic, S Metallic, T series, G series, U series, EH and SH High Pressure, W series, SMA and SPA Submersibles, and Tranquilizer Surge Suppressors comply with the European Community Directive 98/37/EC, Safety of Machinery. This product has used Harmonized Standard EN 809, Pumps and Pump Units for Liquids - Common Safety Requirements, to verify conformance.

David Roseberry

Signature of authorized person

October 20, 2005

Date of issue

David Roseberry

Printed name of authorized person

Engineering Manager

Title

Revision level A

August 6, 2008

Date of revision

CE



Declaration of Conformity