

# SERVICE & OPERATING MANUAL



## Model G1F Metallic Design Level 1

### Natural Gas-Operated Diaphragm Pumps

## Table of Contents

Engineering Data and Temperature Limitations.....	1
Explanation of Pump Nomenclature.....	2
Performance Curve.....	3
Dimensions .....	4
Metric Dimensions .....	5
Principle of Pump Operation.....	6
Installation and Start-Up.....	6
Natural Gas Supply .....	6
Natural Gas Valve Lubrication .....	6
Natural Gas Line Moisture.....	6
Natural Gas Inlet and Priming .....	6
Between Uses .....	6
Installation Guide.....	7
Troubleshooting .....	8
Warranty .....	8
Recycling.....	9
Important Safety Information .....	9
Material Codes .....	10
Composite Repair Parts Drawing .....	12

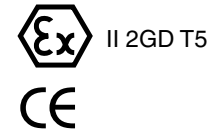

U.S. Patent #  
5,996,627; 6,241,487  
Other U.S. Patents  
Applied for

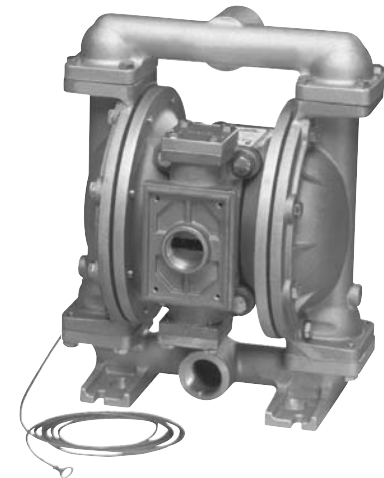

Available Service and Conversion Kits .....	12
Composite Repair Parts List.....	13
Natural Gas Distribution Valve Assembly Drawing and Parts List .....	14
Natural Gas Distribution Valve Servicing .....	15
Pilot Valve Servicing, Assembly Drawing & Parts List .....	16
Diaphragm Service Drawing, with Overlay .....	17
Diaphragm Service Drawing, Non-Overlay .....	17
Diaphragm Servicing .....	18
Overlay Diaphragm Servicing .....	18
Actuator Plunger Servicing.....	19
Check Valve Servicing .....	20
Check Valve Drawing.....	20
Provision for Piping Gas Exhaust .....	21
Pumping Hazardous Liquids.....	21
Piping Exhaust Natural Gas .....	21
Exhaust Illustration .....	21
Grounding The Pump .....	22
CE Declaration of Conformity .....	23
ATEX Declaration of Conformity .....	24



**WARREN  
RUPP®**

Quality System  
ISO9001 Certified

Environmental  
Management System  
ISO14001 Certified

**IDEX**  
FLUID & METERING

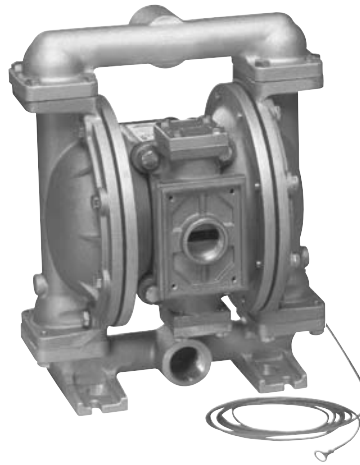

U.S. Patent #  
5,996,627; 6,241,487  
Other U.S. Patents  
Applied for



**SANDPIPER®**

A WARREN RUPP PUMP BRAND

**G1F Metallic**

**Natural Gas-Operated  
Diaphragm Pumps**

ENGINEERING, PERFORMANCE  
& CONSTRUCTION DATA

INTAKE/DISCHARGE PIPE SIZE 1" NPT (internal) 1" BSP Tapered (internal)	CAPACITY 0 to 45 gallons per minute (0 to 170 liters per minute)	GAS VALVE No-lube, no-stall design	SOLIDS-HANDLING Up to .25 in. (6mm)	HEADS UP TO 100 psi or 230.7 ft. of water (7Kg/cm <sup>2</sup> or 70 meters)	DISPLACEMENT/STROKE .11 Gallon / .42 liter
<p><b>⚠ CAUTION! Operating temperature limitations are as follows:</b></p>					
<p><b>Materials</b></p>				Operating Temperatures	
				Maximum	Minimum
<p><b>Nitrile:</b> General purpose, oil-resistant. Shows good solvent, oil, water and hydraulic fluid resistance. Should not be used with highly polar solvents like acetone and MEK, ozone, chlorinated hydrocarbons and nitro hydrocarbons.</p>				190°F 88°C	-10°F -23°C
<p><b>Virgin PTFE:</b> Chemically inert, virtually impervious. Very few chemicals are known to react chemically with PTFE: molten alkali metals, turbulent liquid or gaseous fluorine and a few fluoro-chemicals such as chlorine trifluoride or oxygen difluoride which readily liberate free fluorine at elevated temperatures.</p>				220°F 104°C	-35°F -37°C
<p><b>FKM (Fluorocarbon):</b> Excellent resistance to sour natural gas, high temperatures, acids, hydrogen sulfide, and oils.</p>				400°F 204°F	-15°F -26°F

For specific applications, always consult "Chemical Resistance Chart" Technical Bulletin

These G1F SANDPIPER® models are designed to be powered only by natural gas. The minimum pump operating temperature is -10°F and the maximum operating temperature is 180°F.

# Explanation of Pump Nomenclature

## G1F Metallic · Design Level 1 · Ball Valve

MODEL	Pump Brand	Pump Size	Check Valve Type	Design Level	Wetted Material	Diaphragm/Check Valve Materials	Check Valve Seat	Non-Wetted Material Options	Porting Options	Pump Style	Pump Options	Kit Options	Shipping Weight lbs. (kg)
G1FB1ABTXNSX00.	G	1F	B	1	A	B	T	X	N	S	X	00.	28 (13)
G1FB1ATTXNSX00.	G	1F	B	1	A	T	T	X	N	S	X	00.	28 (13)
G1FB1SBTXNSX00.	G	1F	B	1	S	B	T	X	N	S	X	00.	43 (20)
G1FB1STTXNSX00.	G	1F	B	1	S	T	T	X	N	S	X	00.	43 (20)
G1FB1ABTXBSX00.	G	1F	B	1	A	B	T	X	B	S	X	00.	28 (13)
G1FB1ATTXBSX00.	G	1F	B	1	A	T	T	X	B	S	X	00.	28 (13)
G1FB1SBTXBSX00.	G	1F	B	1	S	B	T	X	B	S	X	00.	43 (20)
G1FB1STTXBSX00.	G	1F	B	1	S	T	T	X	B	S	X	00.	43 (20)
G1FB1ABT0NSX00.	G	1F	B	1	A	B	T	0	N	S	X	00.	28 (13)
G1FB1SBT0NSX00.	G	1F	B	1	S	B	T	0	N	S	X	00.	43 (20)
G1FB1ABT0BSX00.	G	1F	B	1	A	B	T	0	B	S	X	00.	28 (13)
G1FB1SBT0BSX00.	G	1F	B	1	S	B	T	0	B	S	X	00.	43 (20)

**Note: Models listed in the table are for reference only. See nomenclature below for other models.**

### Pump Brand

G= Sweet Gas Operated

### Pump Size

1F=1"

### Check Valve Type

B= Ball

### Design Level

1= Design Level

### Wetted Material

S= Stainless Steel

A= Aluminum

### Diaphragm Check Ball Materials

B= Nitrile/Nitrile

T=PTFE -Nitrile/PTFE

S= Nitrile/PTFE

### Check Valve Seat

T= Virgin PTFE

A= Aluminum

S= Stainless Steel

### Non-Wetted Material Options

A= Painted Aluminum

X= Unpainted Aluminum

0= Unpainted Aluminum/FKM Elastomer

V= Painted Aluminum/ FKM Elastomers

### Porting Options

N=NPT Threads

B= BSP (Tapered) Threads

### Pump Style

S= Standard

### Pump Options

X= No Muffler Permitted \*

These pump models are designed to pump the following fluids: Crude Oil, Salt Water, Drilling Mud, Condensate, Lubrication Oils, Glycol, Caustic liquids, and Acids.

\* The exhausted natural gas must be vented to a low pressure safe location in accordance with local fire safety and environmental codes, an industry or nationally recognized code having jurisdiction over the specific installations, and/or CAN/CGA B149, Installation Codes.

# Performance Curve, G1F Model Metallic Design Level 1

## MODEL G1F Metallic Performance Curve

Performance based on the following: elastomer fitted pump, flooded suction, water at ambient conditions.  
 The use of other materials and varying hydraulic conditions may result in deviations in excess of 5%.

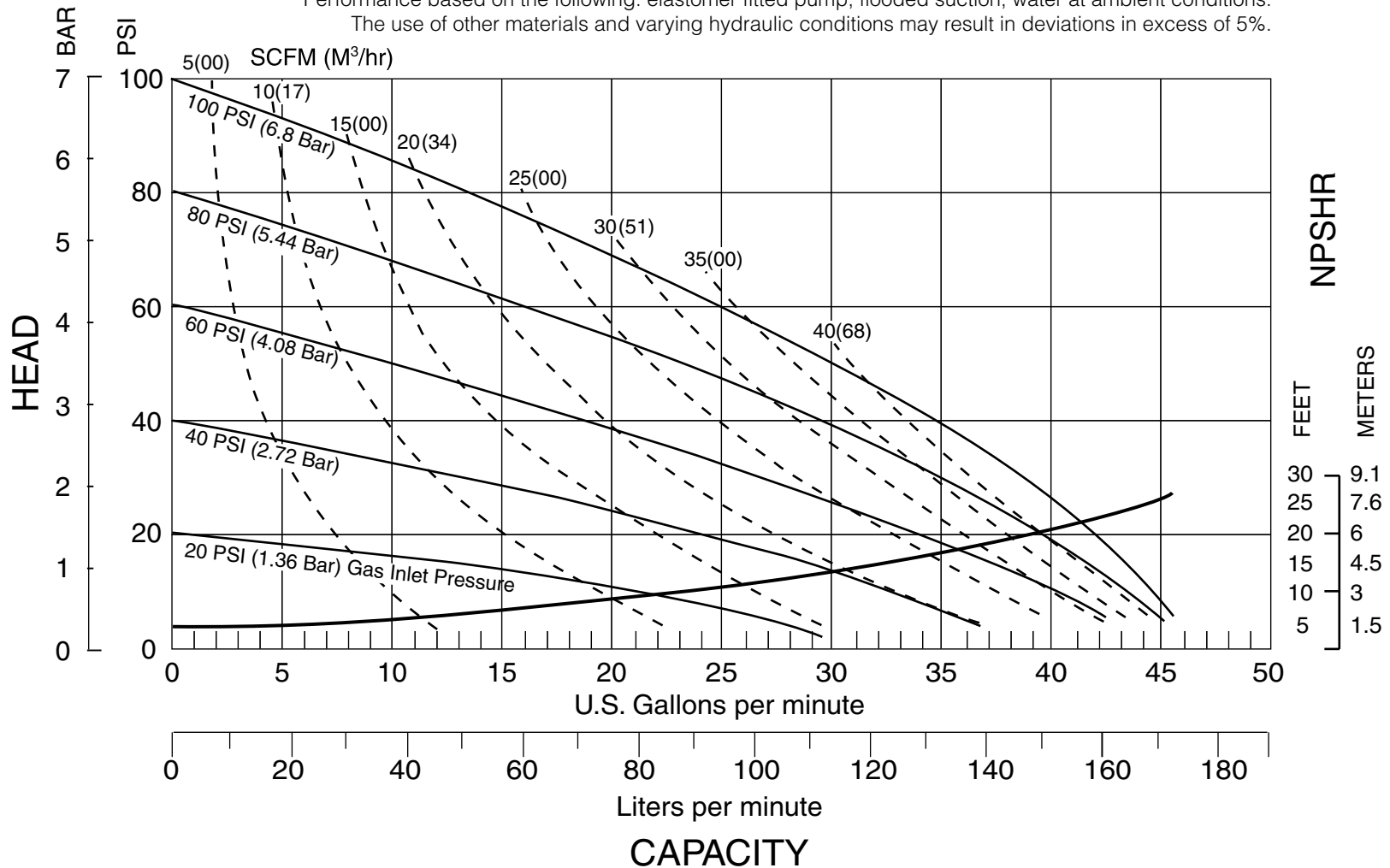

# Dimensions: G1F Model Metallic

Dimensions in Inches

Dimensional Tolerance:  $\pm 1/8"$

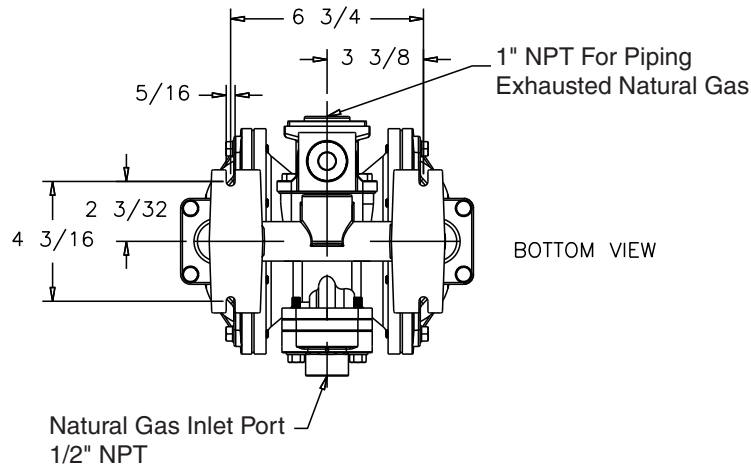
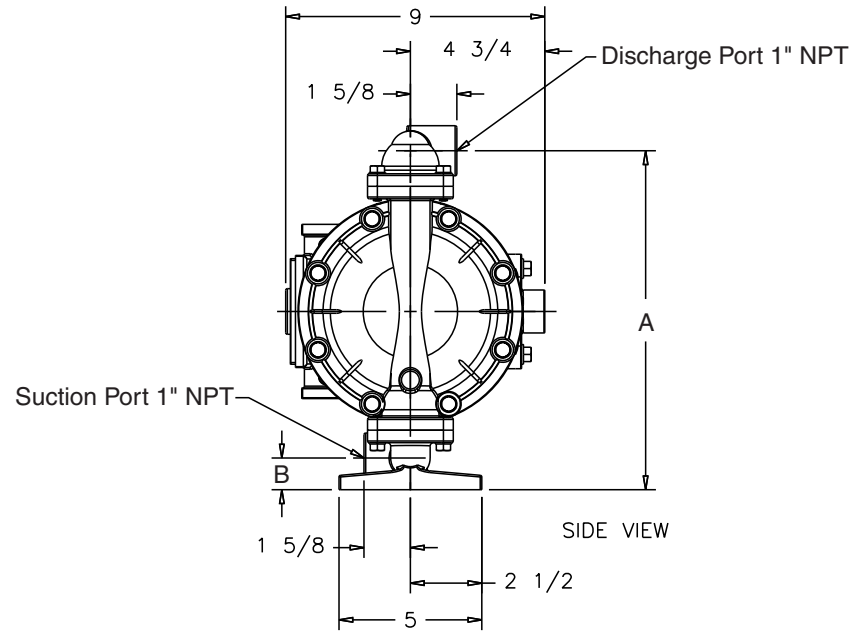
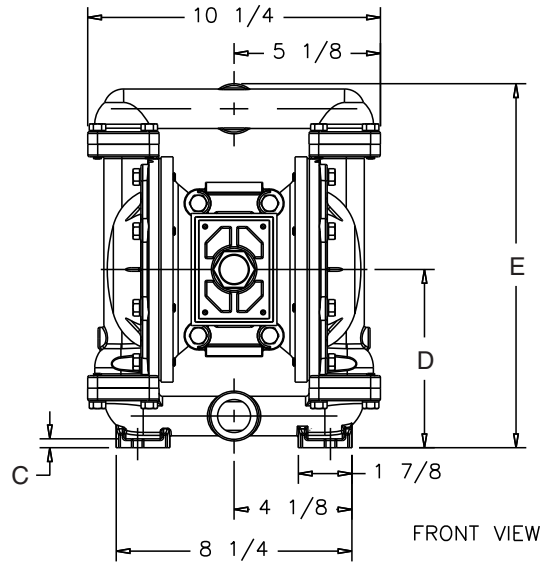

Both Suction and Discharge Ports Are With Available With 1" BSP $\overline{T}$  Tapered Threads.

Dimension	A	B	C	D	E
Aluminum	11 27/32	1 3/32	5/16	6 7/32	12 23/32
Stainless Steel	11 1/32	1 7/32	7/16	6 11/32	12 27/32

**Note: The pump is to be mounted in the horizontal position.**

# Metric Dimensions: G1F Model Metallic

Dimensions in Millimeters  
Dimensional Tolerance:  $\pm 3\text{mm}$

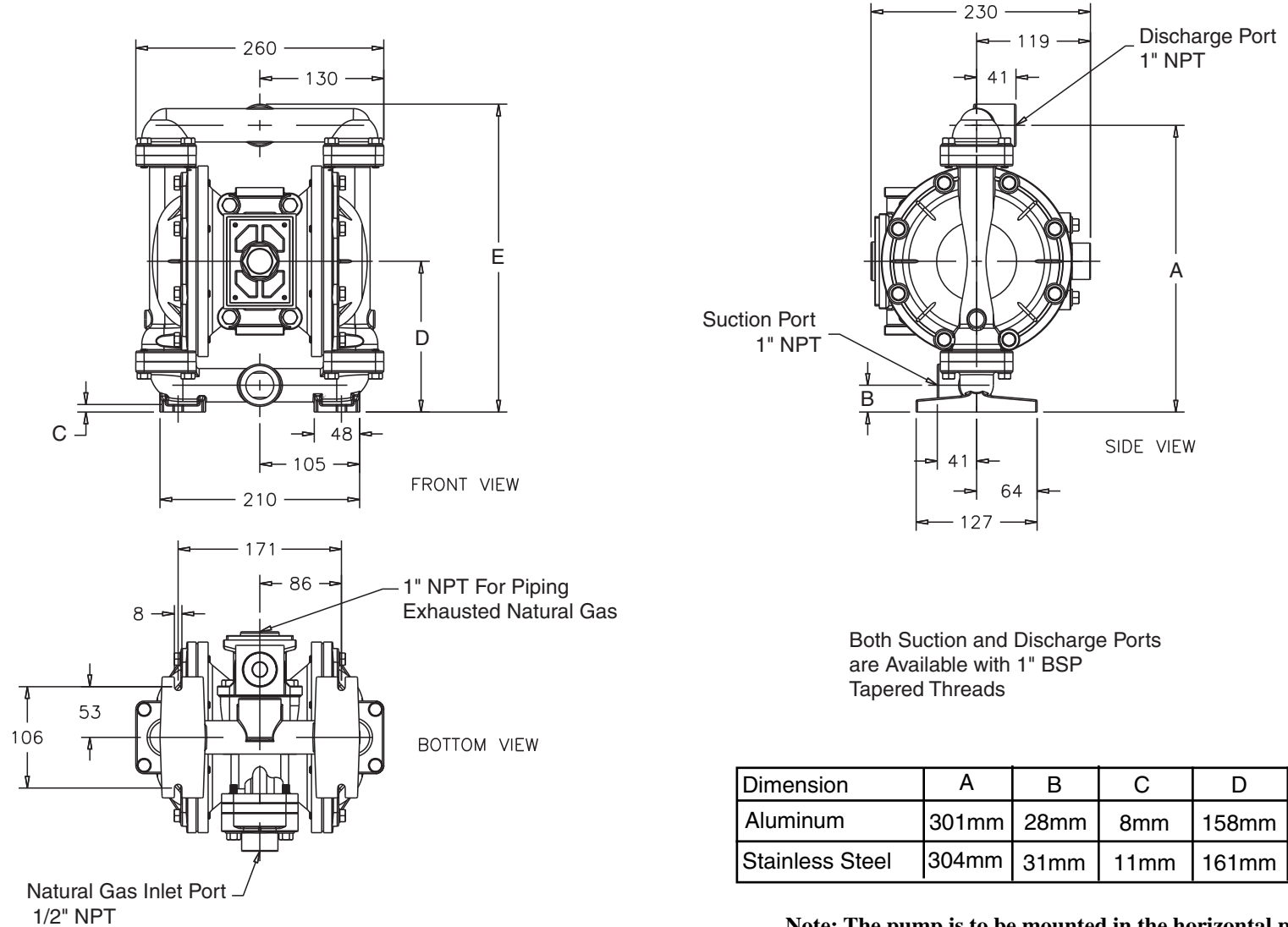

## PRINCIPLE OF PUMP OPERATION

This ball type check valve pump is powered by sweet natural gas and is a 1:1 ratio design. The inner side of one diaphragm chamber is alternately pressurized while simultaneously exhausting the other inner chamber. This causes the diaphragms, which are connected by a common rod secured by plates to the centers of the diaphragms, to move in a reciprocating action. (As one diaphragm performs the discharge stroke the other diaphragm is pulled to perform the suction stroke in the opposite chamber.) Gas pressure is applied over the entire inner surface of the diaphragm while liquid is discharged from the opposite side of the diaphragm. The diaphragm operates in a balanced condition during the discharge stroke which allows the pump to be operated at discharge heads over 200 feet (61 meters) of water.

For maximum diaphragm life, keep the pump as close to the liquid being pumped as possible. Positive suction head in excess of 10 feet of liquid (3.048 meters) may require a back pressure regulating device to maximize diaphragm life.

Alternate pressurizing and exhausting of the diaphragm chamber is performed by an externally mounted, pilot operated, four way spool type gas distribution valve. When the spool shifts to one end of the valve body, inlet

pressure is applied to one diaphragm chamber and the other diaphragm chamber exhausts. When the spool shifts to the opposite end of the valve body, the pressure to the chambers is reversed. The gas distribution valve spool is moved by a internal pilot valve which alternately pressurizes one end of the valve while exhausting the other end. The pilot valve is shifted at each end of the diaphragm stroke when a actuator plunger is contacted by the diaphragm plate. This actuator plunger then pushes the end of the pilot valve spool into position to activate the gas distribution valve.

The chambers are connected with manifolds with a suction and discharge check valve for each chamber, maintaining flow in one direction through the pump.

## INSTALLATION AND START-UP

Locate the pump as close to the product being pumped as possible. Keep the suction line length and number of fittings to a minimum. Do not reduce the suction line diameter.

For installations of rigid piping, short sections of flexible conductive hose should be installed between the pump and the piping. The flexible conductive hose reduces vibration and strain to the pumping system. A surge suppressor is recommended to further reduce pulsation in flow.

## NATURAL GAS SUPPLY

Natural gas inlet pressure must be regulated to 100 (7 bar) psi with a pressure regulator. Connect the pump gas inlet to an gas supply of sufficient capacity and pressure required for desired performance. When the gas supply line is solid piping, use a short length of flexible conductive hose not less than 3/4" (19mm) in diameter between the pump and the piping to reduce strain to the piping. The weight of the gas supply line, regulators and filters must be supported by some means other than the gas inlet cap. Failure to provide support for the piping may result in damage to the pump. A pressure regulating valve should be installed to insure gas supply pressure does not exceed recommended limits.

## VALVE LUBRICATION

The natural gas distribution valve and the pilot valve are designed to operate WITHOUT lubrication. This is the preferred mode of operation. There may be instances of personal preference or poor quality gas supplies when lubrication of the supply is required. The pump system will operate with properly lubricated supply. Proper lubrication requires the use of an gas line lubricator (available from Warren Rupp) set to deliver one drop of SAE 10 non-detergent oil for every 20 SCFM (9.4 liters/sec.) of gas the pump consumes at the point of operation. Consult the pump's published Performance Curve to determine this.

## GAS INLET AND PRIMING

To start the pump, open the gas valve approximately 1/2" to 3/4" turn. After the pump primes, the valve can be opened to increase gas flow as desired. If opening the valve increases cycling rate, but does not increase the rate of flow, cavitation has occurred. The valve should be closed slightly to obtain the most efficient gas flow to pump flow ratio.

## BETWEEN USES

When the pump is used for materials that tend to settle out or solidify when not in motion, the pump should be flushed after each use to prevent damage. (Product remaining in the pump between uses could dry out or settle out. This could cause problems with the diaphragms and check valves at restart.) In freezing temperatures the pump must be completely drained between uses in all cases.



Available from Warren Rupp

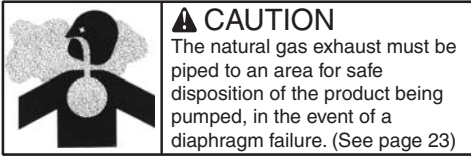

① **020.063.000. Filter**  
**VENTING WARNING:** This filter is equipped with a stainless steel manual drain. The port is 1/8" NPT. When draining moisture from the filter, first shut off the natural gas supply.

② **020.058.000. REGULATOR WITH GAGE**  
**PRESSURE WARNING:** This regulator is to be installed at point of use with the pump. The maximum gas supply is 400psi. Full line pressure needs to be regulated below 400psi prior to the regulator installation position.

**VENTING WARNING:** This regulator is equipped with a 1/4" NPT vent port. In the event of a diaphragm rupture, natural gas can be exhausted into the surrounding environment. Connect a conductive hose or pipe to the vent port to send the escaping natural gas to a safe area for gas reclamation. Make sure to ground the regulator, hose, and/or pipe.

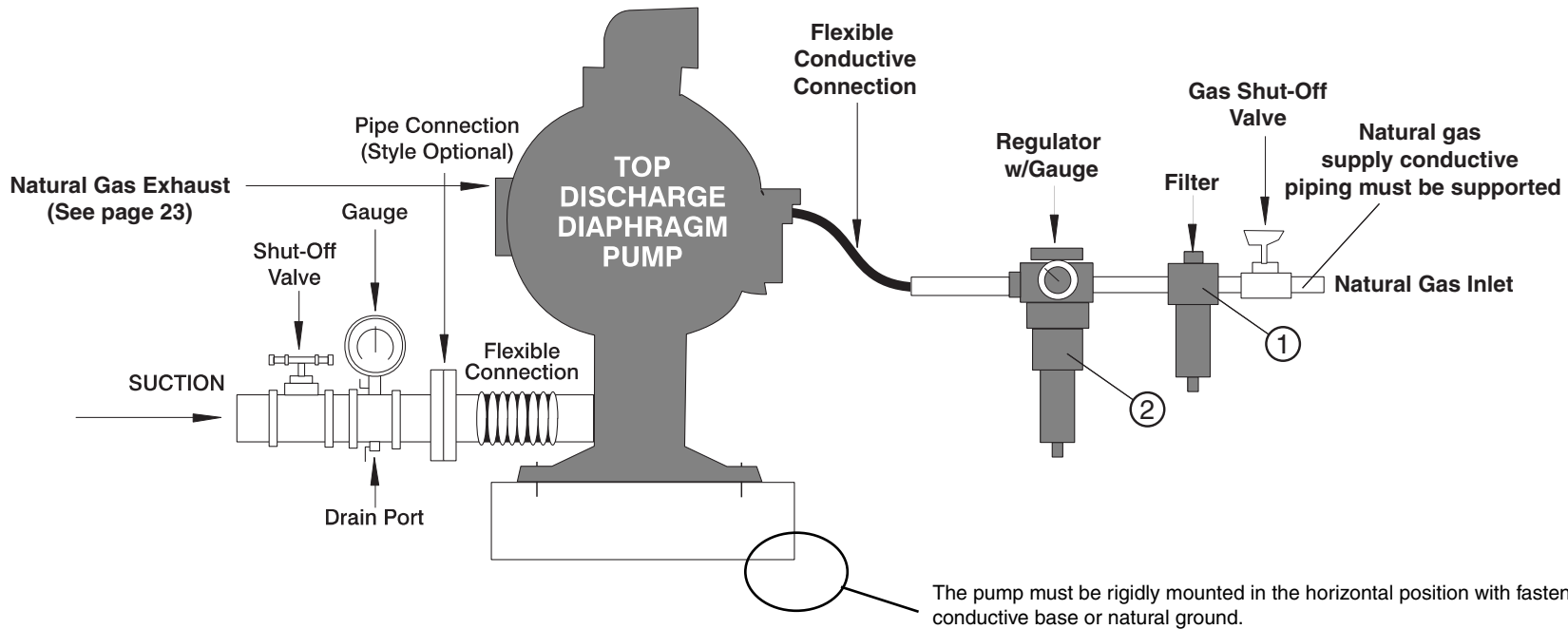

## **TROUBLESHOOTING**

### **Possible Symptoms:**

- Pump will not cycle.
- Pump cycles, but produces no flow.
- Pump cycles, but flow rate is unsatisfactory.
- Pump cycle seems unbalanced.
- Pump cycle seems to produce excessive vibration.

**What to Check:** Excessive suction lift in system.

**Corrective Action:** For lifts exceeding 20 feet (6 meters), filling the pumping chambers with liquid will prime the pump in most cases.

**What to Check:** Excessive flooded suction in system.

**Corrective Action:** For flooded conditions exceeding 10 feet (3 meters) of liquid, install a back pressure device.

**What to Check:** System head exceeds natural gas supply pressure.

**Corrective Action:** Increase the inlet gas pressure to the pump. Most diaphragm pumps are designed for 1:1 pressure ratio at zero flow.

**What to Check:** Natural gas supply pressure or volume exceeds system head.

**Corrective Action:** Decrease inlet gas pressure and volume to the pump as calculated on the published PERFORMANCE CURVE. Pump is cavitating the fluid by fast cycling.

**What to Check:** Undersized suction line.

**Corrective Action:** Meet or exceed pump connection recommendations shown on the DIMENSIONAL DRAWING.

**What to Check:** Restricted or undersized gas line.

**Corrective Action:** Install a larger gas line and connection. Refer to gas inlet recommendations shown in your pump's SERVICE MANUAL.

**What to Check:** Check the externally serviceable gas distribution system of the pump.

**Corrective Action:** Disassemble and inspect the natural gas distribution valve, pilot valve and pilot valve actuators. Refer to the parts drawing and valve section of the SERVICE MANUAL. Check for clogged discharge or closed valve before reassembly.

**What to Check:** Pumped fluid in gas exhaust line.

**Corrective Action:** Disassemble pump chambers. Inspect for diaphragm rupture or loose diaphragm plate assembly. Refer to the Diaphragm Replacement section of your pump SERVICE MANUAL.

**What to Check:** Fluid suction side air leakage or air in product.

**Corrective Action:** Visually inspect all suction side gaskets and pipe connections.

**What to Check:** Obstructed check valve.

**Corrective Action:** Disassemble the wet end of the pump and manually dislodge obstruction in the check valve pocket. Refer to the Check Valve section of the pump SERVICE MANUAL for disassembly instructions.

**What to Check:** Worn or misaligned check valve or check valve seat.

**Corrective Action:** Inspect check valves and seats for wear and proper seating. Replace if necessary. Refer to Check Valve section of the pump SERVICE MANUAL for disassembly instructions.

**What to Check:** Blocked suction line.

**Corrective Action:** Remove or flush obstruction. Check and clear all suction screens and strainers.

**What to Check:** Blocked discharge line.

**Corrective Action:** Check for obstruction or closed discharge line valves.

**What to Check:** Blocked pumping chamber.

**Corrective Action:** Disassemble and inspect the wetted chambers of the pump. Remove or flush any obstructions. Refer to the pump SERVICE MANUAL for disassembly instructions.

**What to Check:** Entrained air or vapor lock in one or both fluid pumping chambers.

**Corrective Action:** Purge chambers through tapped chamber vent plugs. PURGING THE CHAMBERS OF AIR CAN BE DANGEROUS! Contact the Warren Rupp Technical Services Group before performing this procedure. Any model with top-ported discharge will reduce or eliminate problems with entrained air.

If your pump continues to perform below your expectations, contact your local Warren Rupp Distributor or factory Technical Services Group for a service evaluation.

## **WARRANTY**

Refer to the enclosed Warren Rupp Warranty Certificate.

# RECYCLING

Many components of Natural Gas Operated SANDPIPER® Metallic pumps are made of recyclable materials (see chart on page 10 for material specifications). We encourage pump users to recycle worn out parts and pumps whenever possible, after any hazardous pumped fluids are thoroughly flushed.



Certified to CSA Technical Letter No. R-14



Certified to CSA Requirement 2.01 US



Pump complies with EN809 Pumping Directive, Directive 98/37/EC Safety of Machinery, and Directive 94/9/EC, EN13463-1 Equipment for use in Potentially Explosive Environments. For reference to the directive certificates visit: [www.warrenrupp.com](http://www.warrenrupp.com). The Technical File No. AX1 is stored at KEMA, Notified Body 0344, under Document #203040000.



**⚠ WARNING**  
Do not smoke near the pump or use the pump near an open flame. Fire or explosion could result.



**⚠ WARNING**  
This pump must not be used for fluid transfer into aircraft.

# IMPORTANT SAFETY INFORMATION



**⚠ IMPORTANT**  
Read these safety warnings and instructions in this manual completely, before installation and start-up of the pump. It is the responsibility of the purchaser to retain this manual for reference. Failure to comply with the recommendations stated in this manual will damage the pump, and void factory warranty.



**⚠ CAUTION**  
Before pump operation, inspect all gasketed fasteners for looseness caused by gasket creep. Retorque loose fasteners to prevent leakage. Follow recommended torques stated in this manual.



**⚠ WARNING**  
Before maintenance or repair, shut off the compressed natural gas line, bleed the pressure, and disconnect the gas line from the pump. The discharge line may be pressurized and must be bled of its pressure.



**⚠ WARNING**  
In the event of diaphragm rupture, pumped material may enter the natural gas end of the pump, and be discharged into the atmosphere. The gas exhaust must be piped to an appropriate area for safe disposition.



**⚠ WARNING**  
Take action to prevent static sparking. Fire or explosion can result, especially when handling flammable liquids. The pump, piping, valves, containers or other miscellaneous equipment must be grounded.



**⚠ WARNING**  
This pump is pressurized internally with natural gas pressure during operation. Always make certain that all bolting is in good condition and that all of the correct bolting is reinstalled during assembly.



**⚠ WARNING**  
When used for toxic or aggressive fluids, the pump should always be flushed clean prior to disassembly.



**⚠ WARNING**  
Before doing any maintenance on the pump, be certain all pressure is completely vented from the pump, suction, discharge, piping, and all other openings and connections. Be certain the natural gas supply is locked out or made non-operational, so that it cannot be started while work is being done on the pump. Be certain that approved eye protection and protective clothing are worn all times in the vicinity of the pump. Failure to follow these recommendations may result in serious injury or death.



**⚠ WARNING**  
Airborne particles and loud noise hazards. Wear ear and eye protection.

# MATERIAL CODES

## The Last 3 Digits of Part Number

000	Assembly, sub-assembly; and some purchased items	180	Copper Alloy	375	Fluorinated Nitrile	606	PTFE
010	Cast Iron	305	Carbon Steel, Black Epoxy Coated	377	Conductive HNBR	607	Envelon
012	Powered Metal	306	Carbon Steel, Black PTFE Coated	378	High Density Polypropylene	608	Conductive PTFE
015	Ductile Iron	307	Aluminum, Black Epoxy Coated	379	Conductive Nitrile	610	PTFE Encapsulated Silicon
020	Ferritic Malleable Iron	308	Stainless Steel, Black PTFE Coated	405	Cellulose Fibre	611	PTFE Encapsulated FKM
025	Music Wire	309	Aluminum, Black PTFE Coated	408	Cork and Neoprene	632	Neoprene/Hytrel
080	Carbon Steel, AISI B-1112	310	PVDF Coated	425	Compressed Fibre	633	FKM/PTFE
100	Alloy 20	330	Zinc Plated Steel	426	Blue Gard	634	EPDM/PTFE
110	Alloy Type 316 Stainless Steel	331	Chrome Plated Steel	440	Vegetable Fibre	635	Neoprene/PTFE
111	Alloy Type 316 Stainless Steel (Electro Polished)	332	Aluminum, Electroless Nickel Plated	465	Fibre	637	PTFE, FKM/PTFE
112	Alloy C (Hastelloy equivalent)	333	Carbon Steel, Electroless Nickel Plated	500	Delrin 500	638	PTFE, Hytrel/PTFE
113	Alloy Type 316 Stainless Steel (Hand Polished)	334	Cast Iron, Electroless Nickel Plated	501	Delrin 570	639	Nitrile/TFE
114	303 Stainless Steel	335	Galvanized Steel	502	Conductive Acetal, ESD-800	643	Santoprene®/EPDM
115	302/304 Stainless Steel	336	Zinc Plated Yellow Brass	503	Conductive Acetal, Glass-Filled	644	Santoprene®/PTFE
117	440-C Stainless Steel (Martensitic)	337	Silver Plated Steel	505	Acrylic Resin Plastic	649	PTFE Nitrile/PTFE
120	416 Stainless Steel (Wrought Martensitic)	340	Nickel Plated	506	Delrin 150	656	Santoprene Diaphragm and Check Balls/EPDM Seats
123	410 Stainless Steel (Wrought Martensitic)	342	Filled Nylon	520	Injection Molded PVDF Natural color		
148	Hardcoat Anodized Aluminum	353	Geolast; Color: Black	540	Nylon		
149	2024-T4 Aluminum	354	Injection Molded #203-40 Santoprene- Duro 40D +/-5; Color: RED	541	Nylon		
150	6061-T6 Aluminum	355	Thermal Plastic	542	Nylon		
151	6063-T6 Aluminum	356	Hytrel	544	Nylon Injection Molded		
152	2024-T4 Aluminum (2023-T351)	357	Injection Molded Polyurethane	550	Polyethylene		
154	Almag 35 Aluminum	358	Urethane Rubber (Some Applications) (Compression Mold)	551	Glass Filled Polypropylene		
155	356-T6 Aluminum	359	Urethane Rubber	552	Unfilled Polypropylene		
156	356-T6 Aluminum	360	Nitrile Rubber. Color coded: RED	553	Unfilled Polypropylene		
157	Die Cast Aluminum Alloy #380	361	Nitrile	555	Polyvinyl Chloride		
158	Aluminum Alloy SR-319	363	FKM (Fluorocarbon). Color coded: YELLOW	556	Black Vinyl		
159	Anodized Aluminum	364	E.P.D.M. Rubber. Color coded: BLUE	558	Conductive HDPE		
162	Brass, Yellow, Screw Machine Stock	365	Neoprene Rubber. Color coded: GREEN	570	Rulon II		
165	Cast Bronze, 85-5-5-5	366	Food Grade Nitrile	580	Ryton		
166	Bronze, SAE 660	368	Food Grade EPDM	590	Valox		
170	Bronze, Bearing Type, Oil Impregnated	370	Butyl Rubber. Color coded: BROWN	591	Nylatron G-S		
175	Die Cast Zinc	371	Philthane (Tuftane)	592	Nylatron NSB		
		374	Carboxylated Nitrile	600	PTFE (virgin material) Tetrafluorocarbon (TFE)		
				601	PTFE (Bronze and moly filled)		
				602	Filled PTFE		
				603	Blue Gylon		
				604	PTFE		

Delrin and Hytrel are registered tradenames of E.I. DuPont.

Gylon is a registered tradename of Garlock, Inc.

Nylatron is a registered tradename of Polymer Corp.

Santoprene is a registered tradename of Monsanto Corp.

Rulon II is a registered tradename of Dixion Industries Corp.

Ryton is a registered tradename of Phillips Chemical Co.

Valox is a registered tradename of General Electric Co.

Warren Rupp, SANDPIPER, PortaPump, Tranquilizer and SludgeMaster are registered tradenames of Warren Rupp, Inc.



# Composite Repair Parts Drawing

## Available Service Kits:

**476.228.000 Gas End Kit**  
 Seals, O-Rings, Gaskets, Retaining Rings, Valve Assembly and Pilot Valve Assembly

**476.228.363 Gas End Kit**  
 FKM Seals, O-Rings, Gaskets, Retaining Rings, Valve Assembly and Pilot Valve Assembly

**476.204.360 Wetted End Kit**  
 Nitrile Diaphragms, Nitrile Check Balls and PTFE Check Valve Seats

**476.204.649 Wetted End Kit**  
 Nitrile Diaphragms, PTFE Overlay Diaphragms, PTFE Check Balls and PTFE Check Valve Seats

**476.204.672 Wetted End Kit**  
 Nitrile Diaphragms, PTFE Check Balls and PTFE Check Valve Seats

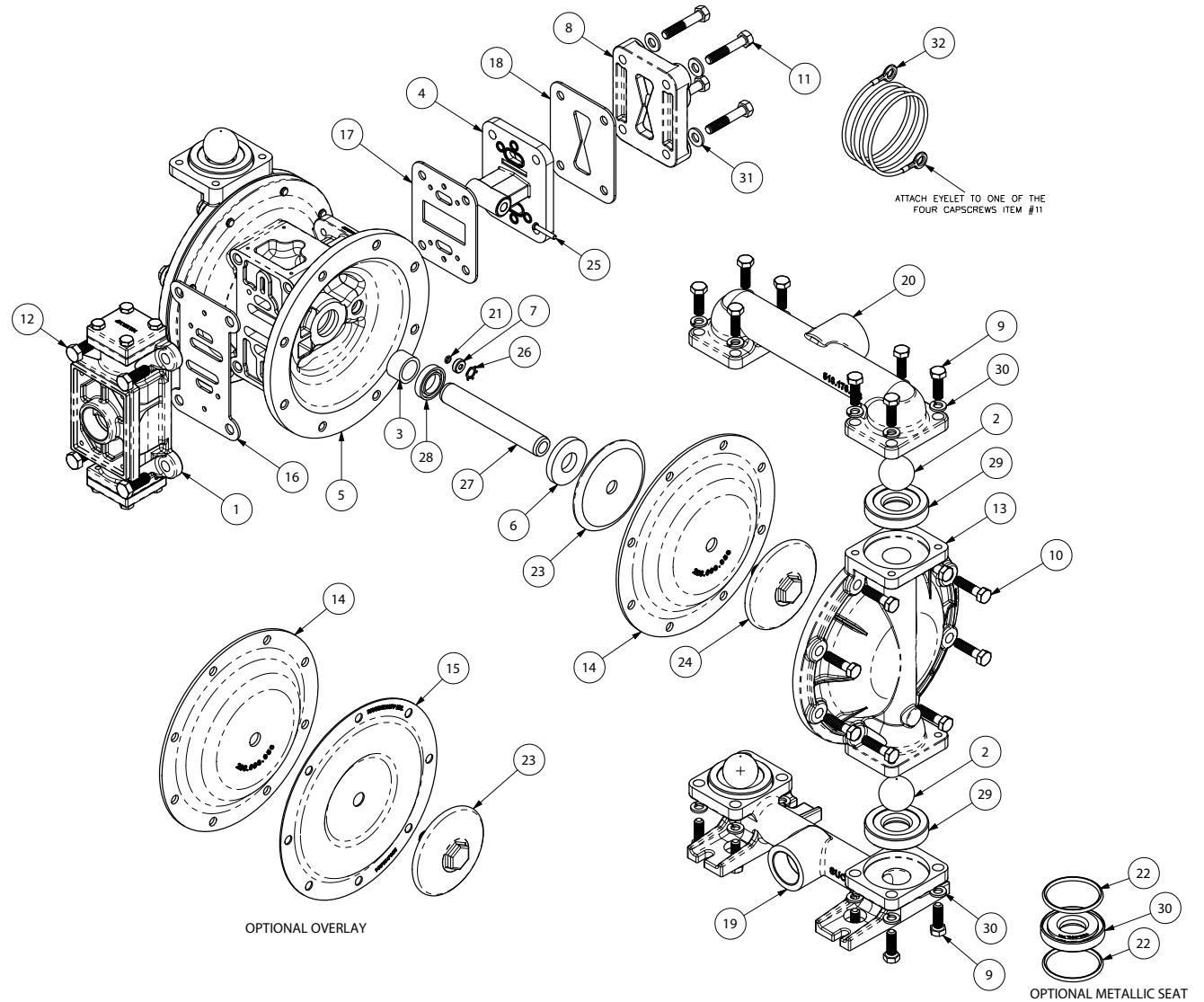

# Composite Repair Parts List

ITEM	PART NUMBER	DESCRIPTION	QTY	ITEM	PART NUMBER	DESCRIPTION	QTY
1	031-183-000	Gas Valve Assembly	1	19	518-175-156	Manifold, Suction	1
	031-183-363	Gas Valve Assembly	1		518-175-156E	Manifold, Suction 1"BSP (Tapered)	1
2	050-028-360	Ball, Check	4		518-175-110	Manifold, Suction	1
	050-028-600	Ball, Check	4		518-175-110E	Manifold, Suction 1"BSP (Tapered)	1
3	070-012-170	Bushing	2	20	518-176-156	Manifold, Discharge	1
4	095-110-000	Pilot Valve Assembly	1		518-176-156E	Manifold, Discharge 1"BSP (Tapered)	1
	095-110-363	Pilot Valve Assembly	1		518-176-110	Manifold, Discharge	1
5	114-025-157	Intermediate Bracket	1		518-176-110E	Manifold, Discharge 1"BSP (Tapered)	1
6	132-019-360	Bumper, Diaphragm	2	21	560-001-363	O-ring	2
	132-019-363	Bumper, Diaphragm	2		560-001-379	O-ring	2
7	135-036-506	Bushing, Plunger	2	22	560-091-360	O-ring (metallic seats only)	8
8	165-120-000	Cap, Gas Inlet Assembly	1		560-091-611	O-ring (metallic seats only)	8
9	170-044-330	Capscrew, Hex Hd 5/16-18 X .1.00	16	23	612-022-330	Plate, Inner Diaphragm	2
10	170-045-330	Capscrew, Hex Hd 5/16-18 X 1.25	16	24	612-108-157	Plate, Outer Diaphragm Assembly	2
11	170-069-330	Capscrew, Hex Hd 5/16-18 X 1.75	4		612-101-110	Plate, Outer Diaphragm Assembly	2
12	170-006-330	Capscrew, Hex 3/8-16 X 1.00	4	25	620-022-115	Pin, Actuator	2
13	196-173-157	Chamber, Outer	2	26	675-042-115	Ring, Retaining	2
	196-173-110	Chamber, Outer	2	27	685-060-110	Rod, Diaphragm	1
14	286-008-360	Diaphragm	2	28	720-010-363	Seal, U-Cup	2
15	286-015-604	Diaphragm, Overlay	2		720-010-375	Seal, U-Cup	2
16	360-093-360	Gasket, Natural Gas Valve	1	29	722-098-600	Seat, Check Valve	4
17	360-103-360	Gasket, Pilot Valve	1		722-098-150	Seat, Check Valve	4
18	360-104-379	Gasket, Gas Inlet	1		722-098-150	Seat, Check Valve	4
				30	900-004-330	Washer, Lock, 5/16	16
				31	901-038-330	Flat, Washer	4
				32	920-025-000	Ground Strap	1

# Natural Gas Valve Assembly Drawing, Parts List

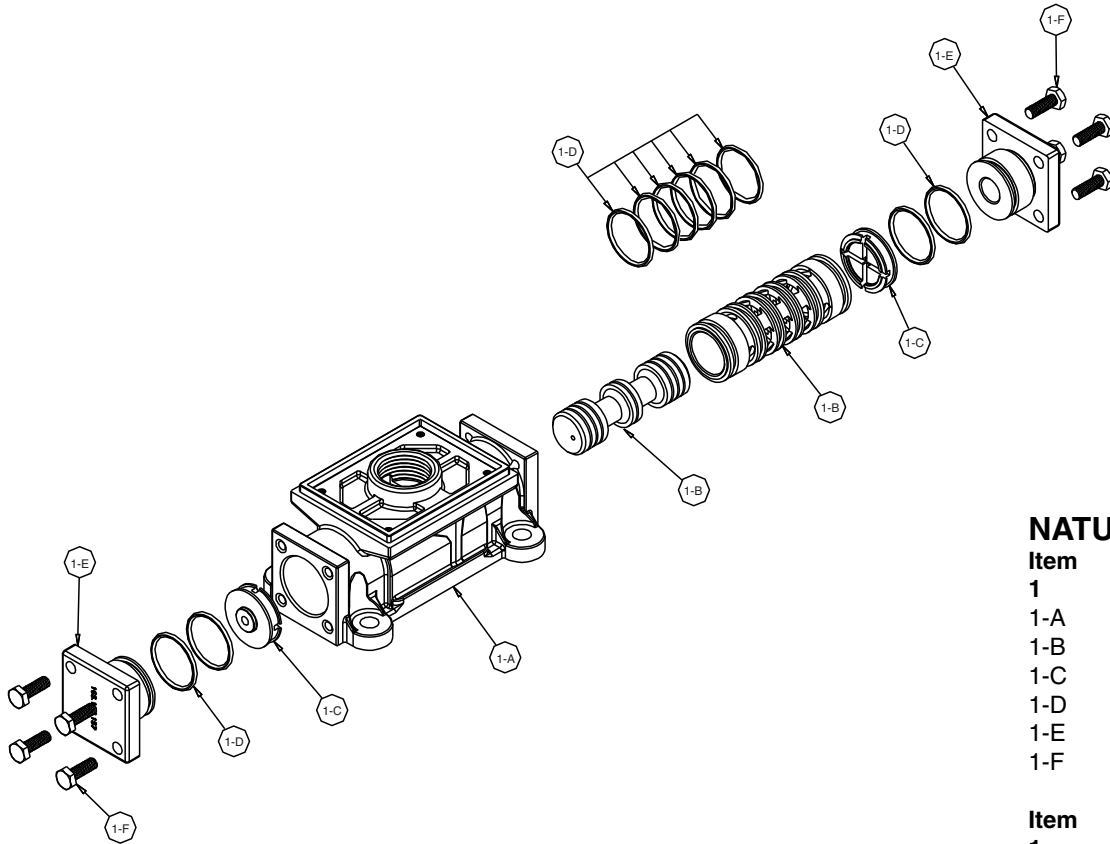

## NATURAL GAS Assembly Parts List

Item	Part Number	Description	Qty
<b>1</b>	<b>031-183-000</b>	<b>Gas Valve Assembly</b>	<b>1</b>
1-A	095-109-157	Valve Body	1
1-B	031-139-000	Sleeve and Spool Set	1
1-C	132-029-357	Bumper	2
1-D	560-020-360	O-ring	10
1-E	165-127-157	Cap, End	2
1-F	170-032-330	Capscrew	8

Item	Part Number	Description	Qty
<b>1</b>	<b>031-183-363</b>	<b>Gas Valve Assembly</b>	<b>1</b>
1-D	560-020-363	O-ring	10

(Included all other items used on 031.183.000)

## NATURAL GAS DISTRIBUTION VALVE SERVICING

To service the natural gas valve first shut off the compressed air, bleed pressure from the pump, and disconnect the gas supply line from the pump.

### Step #1: See COMPOSITE REPAIR PARTS DRAWING.

Using a 9/16" wrench or socket, remove the four hex capscrews (items 12). Remove the air valve assembly from the pump.

Remove and inspect gasket (item 16) for cracks or damage. Replace gasket if needed.

### Step #2: Disassembly of the natural gas valve.

Using a 7/16" wrench or socket, remove the eight hex capscrews (items 1-F) that fasten the end caps to the valve body. Next remove the two end caps (items 1-E). Inspect the two o-rings (items 1-D) on each end cap for damage or wear. Replace the o-rings as needed.

Remove the bumpers (items 1-C). Inspect the bumpers for damage or wear. Replace the bumpers as needed.

Remove the spool (part of item 1-B) from the sleeve. Be careful not to scratch or damage the outer diameter of the spool. Wipe spool with a soft cloth and inspect for scratches or wear.

Inspect the inner diameter of the sleeve (part of item 1-B) for dirt, scratches, or other contaminants. Remove the sleeve if needed and replace with a new sleeve and spool set (item 1-A).

### Step #3: Reassembly of the natural gas valve.

Install one bumper (item 1-C) and one end cap (item 1-E), with two o-rings (items 1-D), and fasten with four hex capscrews (items 1-F) to the valve body (item 1-A).

Remove the new sleeve and spool set (item 1-B) from the plastic bag. Carefully remove the spool from the sleeve. Install the six o-rings (item 1-D) into the six grooves on the sleeve. Apply a light coating of grease to the o-rings before installing the sleeve into the valve body (item 1-A), align the slots in the sleeve with the slots in the valve body. Insert the spool into the sleeve. Be careful not to scratch or damage the spool during installation. Install the remaining bumper and end cap (with o-rings), and fasten with the remaining hex capscrews.

Fasten the natural gas valve assembly (item 1) and gasket to the pump. Connect the compressed gas line to the pump. The pump is now ready for operation.



## ! IMPORTANT

*Read these instructions completely, before installation and start-up. It is the responsibility of the purchaser to retain this manual for reference. Failure to comply with the recommendations stated in this manual will damage the pump, and void factory warranty.*

# Pilot Valve Servicing, Assembly Drawing & Parts List

## PILOT VALVE ASSEMBLY PARTS LIST

ITEM	PART NUMBER	DESCRIPTION	QTY
4	095-110-000	Pilot Valve Assembly	1
4-A	095-095-157	Valve Body	1
4-B	755-052-000	Sleeve (With O-rings)	1
4-C	560-033-360	O-ring (Sleeve)	6
4-D	775-055-000	Spool (With O-rings)	1
4-E	560-023-360	O-ring (Spool)	3
4-F	675-037-080	Retaining Ring	1

ITEM	PART NUMBER	DESCRIPTION	QTY
4	095-110-363	Pilot Valve Assembly	1
4-B	755-052-363	Sleeve (With O-rings)	1
4-C	560-033-363	O-ring (Sleeve)	6
4-E	560-023-363	O-ring (Spool)	3

(includes all other items used on 095-110-000)

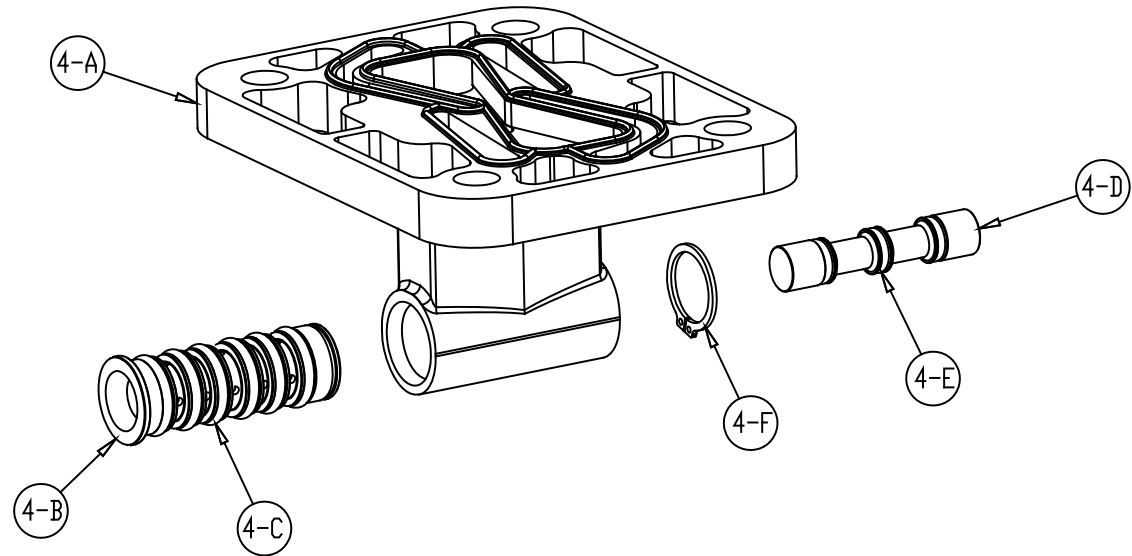

### PILOT VALVE SERVICING

To service the pilot valve first shut off the compressed air supply, bleed the pressure from the pump, and disconnect the air supply line from the pump.

**STEP #1:** See pump assembly drawing.

Using a 1/2" wrench or socket, remove the four capscrews (item 11). Remove the air inlet cap (item 8) and air inlet gasket (item 18). The pilot valve assembly (item 4) can now be removed for inspection and service.

**STEP #2:** Disassembly of the pilot valve.

Remove the pilot valve spool (item 4-D). Wipe clean and inspect spool and o-rings for dirt, cuts or wear. Replace the o-rings and spool if necessary.

Remove the retaining ring (item 4-F) from the end of the sleeve (item 4-B) and remove the sleeve from the valve body (item 4-A). Wipe clean and inspect sleeve and o-rings for dirt, cuts or wear. Replace the o-rings and sleeve if necessary.

**STEP #3:** Re-assembly of the pilot valve.

Generously lubricate outside diameter of the sleeve and o-rings. Then carefully insert sleeve into valve body. Take CAUTION when inserting sleeve, not to shear any o-rings. Install retaining ring to sleeve. Generously lubricate outside diameter of spool and o-rings. Then carefully insert spool into sleeve. Take CAUTION when inserting spool, not to shear any o-rings. Use BP-LS-EP-2 multipurpose grease, or equivalent.

**STEP #4:** Re-install the pilot valve assembly into the intermediate.

Be careful to align the ends of the pilot valve stem between the plunger pins when inserting the pilot valve into the cavity of the intermediate.

Re-install the gasket, air inlet cap and capscrews. Connect the air supply to the pump. The pump is now ready for operation.

# Diaphragm Service Drawing, with Overlay

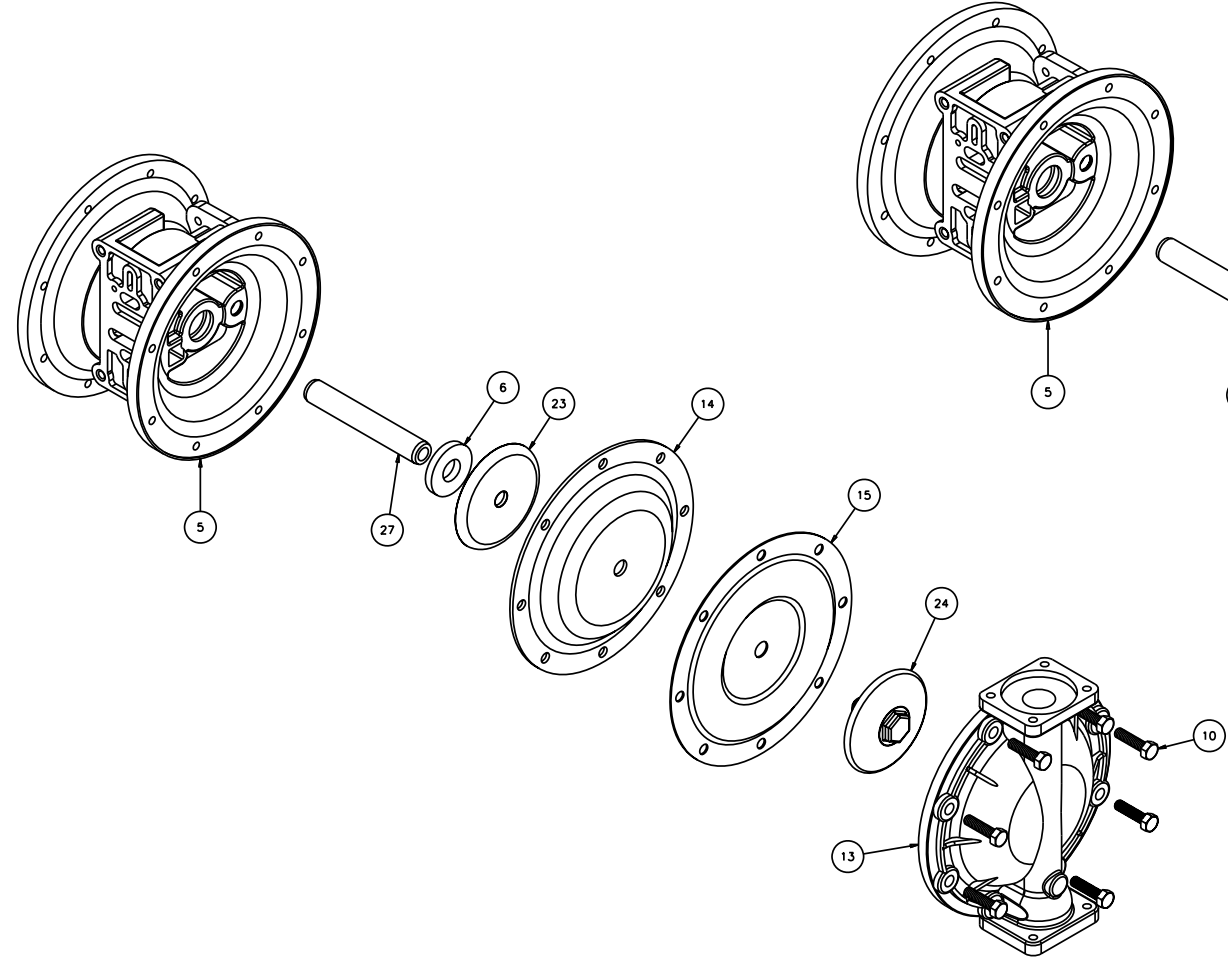

# Diaphragm Service Drawing, Non-Overlay

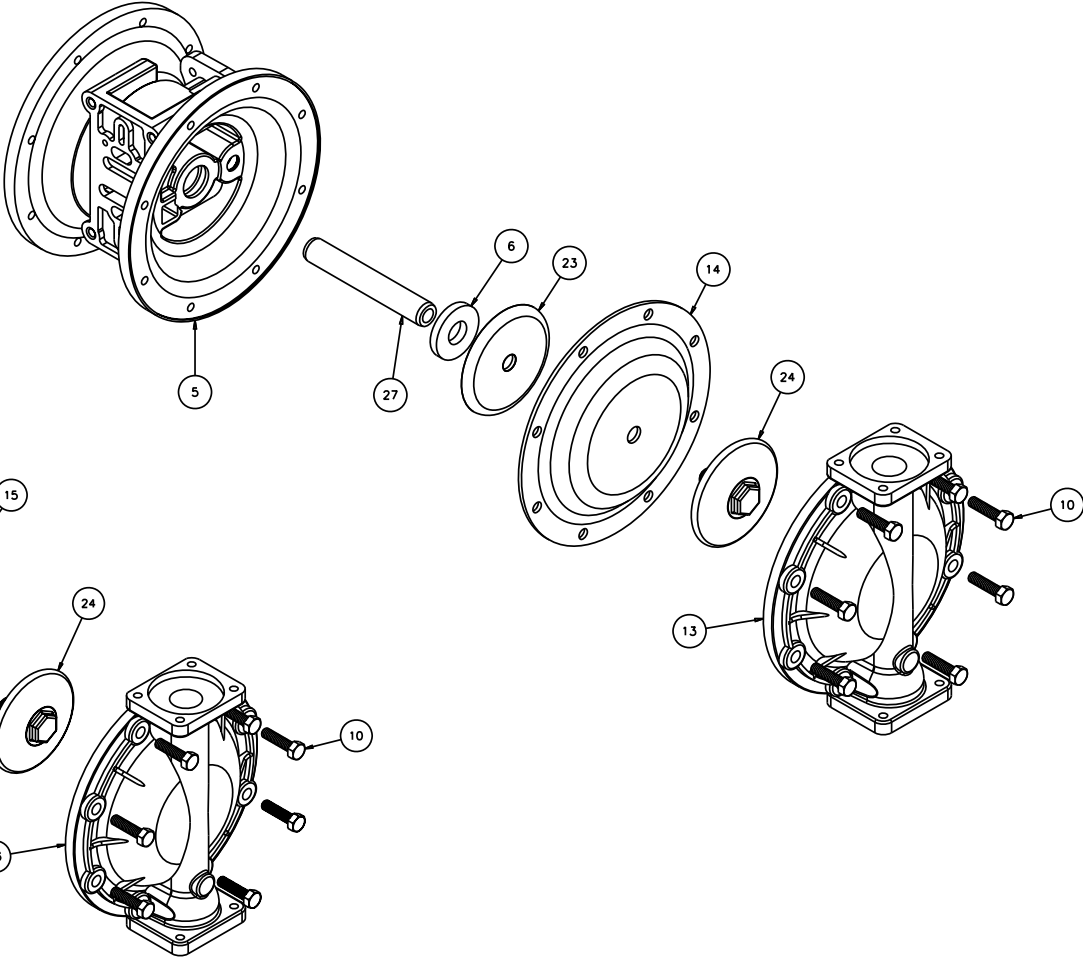

## DIAPHRAGM SERVICING

To service the diaphragms first shut off the suction, then shut off the discharge lines to the pump. Shut off the natural gas supply, bleed the pressure from the pump and disconnect the natural gas supply line from the pump. Drain any remaining liquid from the pump.

**Step #1:** See the pump assembly drawing and the diaphragm servicing illustration.

Using a 1/2" wrench or socket, remove the 16 capscrews (item 9) that fasten the manifolds (items 19 & 20) to the outer chambers (item 13).

**Step #2:** Removing outer chambers.

Using a 1/2" wrench or socket, remove the 16 capscrews (item 10), that fasten the outer chambers (item 13), diaphragms (item 14) and intermediate (item 5) together.

**Step #3:** Removing the diaphragms and diaphragm plates.

Use a 7/8" wrench or six point socket to remove the outer diaphragm plate assemblies (item 24), diaphragms (item 14) and inner diaphragm plates (item 23) from the diaphragm rod (item 27) by turning counterclockwise. Inspect the diaphragm for cuts, punctures, abrasive wear or chemical attack. Replace the diaphragms if necessary. **DO NOT USE A WRENCH ON THE DIAPHRAGM ROD. FLAWS ON THE SURFACE MAY DAMAGE BEARINGS AND SEALS.**

**Step #4:** Assembling the diaphragm and diaphragm plates to the diaphragm rod.

Push the threaded stud of one outer diaphragm plate assembly through the center of one diaphragm and through one inner diaphragm plate. Install the diaphragm with the natural bulge facing away from the diaphragm rod and make sure the radius on the inner diaphragm plate is towards the diaphragm, as indicated on the diaphragm servicing illustration. Thread the assembly onto the diaphragm rod, leaving loose.

**Step #5:** Installing the diaphragm and rod assembly to the pump.

Make sure the bumper (item 6) is installed over the diaphragm rod. Insert rod into pump.

On the opposite side of the pump, pull the diaphragm rod out as far as possible. Make sure the second bumper is installed over the diaphragm rod.

Push the threaded stud of the other outer diaphragm plate assembly through the center of the other diaphragm and through the other inner diaphragm plate. Make sure the radius on the inner diaphragm plate is towards the diaphragm. Thread the assembly onto the diaphragm rod. Use a 7/8" wrench or socket to hold one outer diaphragm plate. Then, use a torque wrench to tighten the other outer diaphragm plate to the diaphragm rod to 500 in. lbs. (56.5 Newton meters).

Align one diaphragm with the intermediate and install the outer chamber to the pump using the 8 capscrews. Tighten the opposite diaphragm plate until the holes in the diaphragm align with the holes in the intermediate. Then, install the other outer chamber using the 8 capscrews.

**Step #6:** Reinstall the manifolds to the pump using the 16 capscrews.

The pump is now ready to be reinstalled, connected and returned to operation.

## OVERLAY DIAPHRAGM SERVICING

The overlay diaphragm (item 15) is designed to fit over the exterior of the standard diaphragm (item 14).

Follow the same procedures described for the standard diaphragm for removal and installation, except tighten the outer diaphragm plate assembly, diaphragms and inner diaphragm plate to the diaphragm rod to 500 in. lbs. (56.5 Newton meters).

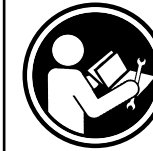

## ! IMPORTANT

*Read these instructions completely, before installation and start-up. It is the responsibility of the purchaser to retain this manual for reference. Failure to comply with the recommendations stated in this manual will damage the pump, and void factory warranty.*

## ACTUATOR PLUNGER SERVICING

To service the actuator plunger first shut off the compressed natural gas supply, bleed the pressure from the pump, and disconnect the natural gas supply line from the pump.

**Step #1:** See PUMP ASSEMBLY DRAWING.

Using a 1/2" wrench or socket, remove the four capscrews (items 11). Remove the gas inlet cap (item 8) and gas inlet gasket (item 18). The pilot valve assembly (item 4) can now be removed.

**Step #2:** Inspect the actuator plungers.

See ILLUSTRATION AT RIGHT.

The actuator plungers (items 25) can be reached through the pilot valve cavity in the intermediate assembly (item 5).

Remove the plungers (item 25) from the bushings (item 7) in each end of the cavity. Inspect the installed o-ring (items 21) for cuts and/or wear. Replace the o-rings if necessary. Apply a light coating of grease to each o-ring and re-install the plungers in to the bushings. Push the plungers in as far as they will go.

To remove the bushings (item 7), first remove the retaining rings (item 26) by using a flat screwdriver.

**NOTE:** It is recommended that new retaining rings be installed.

**Step #3:** Re-install the pilot valve assembly into the intermediate assembly.

Be careful to align the ends of the stem between the plungers when inserting the stem of the pilot valve into the cavity of the intermediate.

Re-install the gasket (item 18), natural gas inlet cap (item 8) and capscrews (item 11).

Connect the natural gas supply to the pump. The pump is now ready for operation.

## ACTUATOR PLUNGER SERVICING

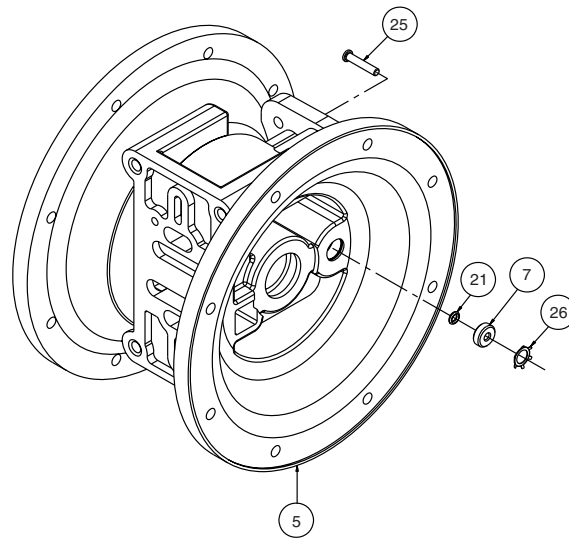

## IMPORTANT

*Read these instructions completely, before installation and start-up. It is the responsibility of the purchaser to retain this manual for reference. Failure to comply with the recommendations stated in this manual will damage the pump, and void factory warranty.*

## CHECK VALVE SERVICING

Before servicing the check valve components, first shut off the suction line and then the discharge line to the pump. Next, shut off the compressed natural gas supply, bleed natural gas pressure from the pump, and disconnect the natural gas supply line from the pump. Drain any remaining fluid from the pump. The pump can now be removed for service.

To access the check valve components, remove the manifolds (item 19 not shown). Use a 9/16" wrench or socket to remove the fasteners. Once the manifold is removed, the check valve components can be seen.

Inspect the check balls (items 2) for wear, abrasion, or cuts on the spherical surface. The check valve seats (item 29) should be inspected for cuts, abrasive wear, or embedded material on the surfaces of both the external and internal chambers. The spherical surface of the check balls must seat flush to the surface of the check valve seats for the pump to operate to peak efficiency. Replace any worn or damaged parts as necessary.

Re-assemble the check valve components. The seat should fit into the counter bore of the outer chamber.

The pump can now be reassembled, reconnected and returned to operation.

## Check Valve Drawing

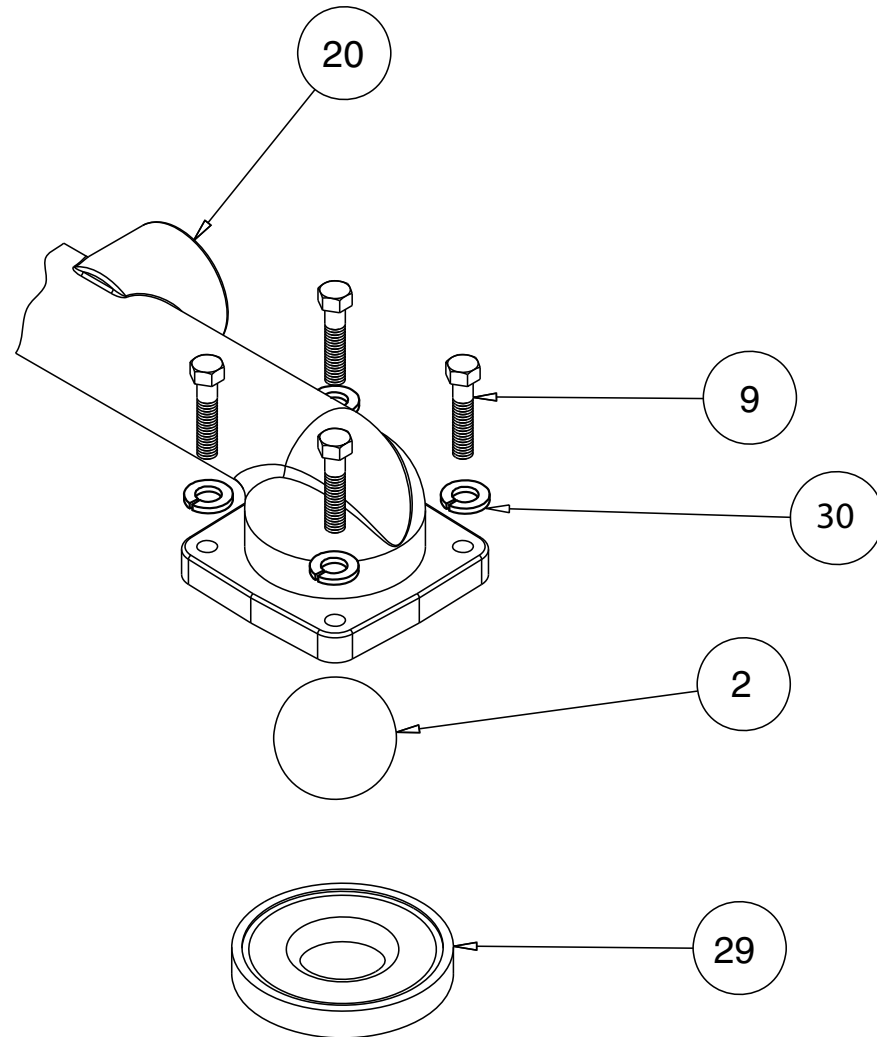

## PUMPING HAZARDOUS LIQUIDS

When a diaphragm fails, the pumped liquid or fumes enter the natural gas end of the pump. Fumes are exhausted into the surrounding environment. When pumping hazardous or toxic materials, the exhaust gas must be piped to an appropriate area for safe disposal. See illustration #1 at right.

This pump can be submerged if the pump materials of construction are compatible with the liquid being pumped. The natural gas exhaust must be piped above the liquid level. See illustration #2 at right. Piping used for the gas exhaust must not be smaller than 1" (2.54 cm) diameter. Reducing the pipe size will restrict natural gas flow and reduce pump performance. When the pumped product source is at a higher level than the pump (flooded suction condition), pipe the exhaust gas higher than the product source to prevent siphoning spills. See illustration #3 at right.

## PIPING THE NATURAL GAS EXHAUST

The following steps are necessary to pipe the exhaust gas away from the pump.

The gas distribution valve assembly (item 1) has 1" NPT threads for piped exhaust.

### IMPORTANT INSTALLATION NOTE:

The manufacturer recommends installing a flexible conductive hose or connection between the pump and any rigid plumbing. This reduces stresses on the molded threads of the natural

gas exhaust port. Failure to do so may result in damage to the natural gas distribution valve body.

Any piping or hose connected to the pump's natural gas exhaust port must be conductive and physically supported. Failure to support these connections could also result in damage to the valve body.

If a high pressure gas spike is possible through the exhaust line, a pressure regulator is required in the exhaust piping.

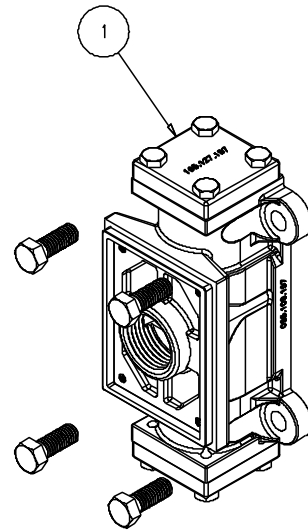



**WARNING**

*Natural gas exhaust is to be vented to low pressure safe location using conductive Nitrile rubber hose or metal piping in accordance with local fire and environmental codes, or an industry or nationally recognized code having jurisdiction over specific installations, and/or CAN/CGA B149, Installation Codes.*

## NATURAL GAS EXHAUST ILLUSTRATION

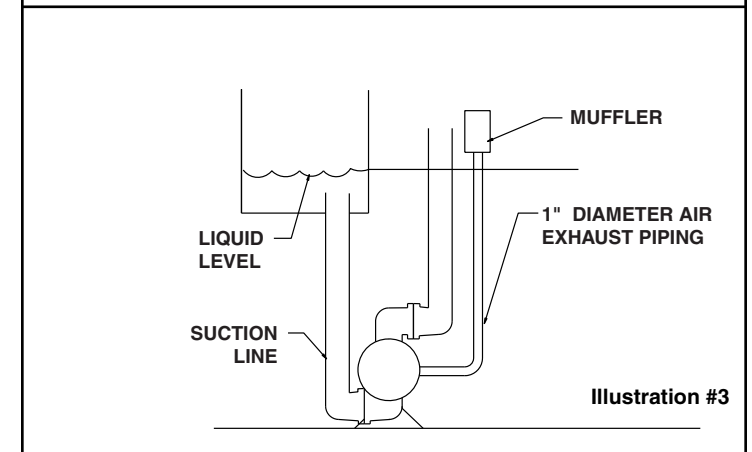
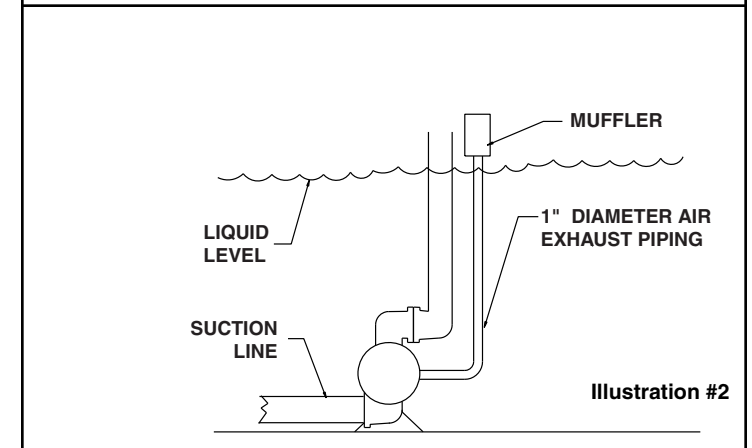
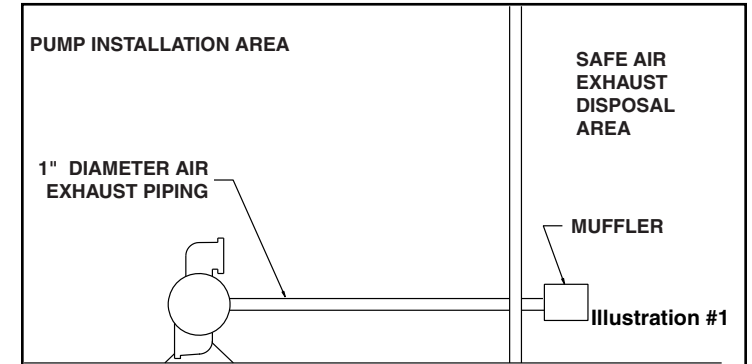

# Grounding The Pump

To be fully groundable, the pumps must be ATEX Compliant. Refer to pump data sheet for ordering.

One eyelet is installed to a true earth ground. (Requires a maximum 5/16 or 8mm maximum diameter bolt)

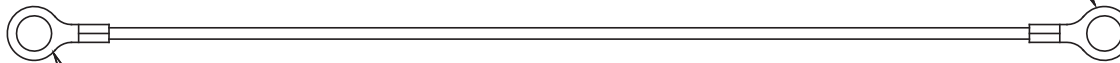

One eyelet is fastened to the pump hardware.

This 8 foot long (244 centimeters) Ground Strap (Item 32) is shipped with the eyelet end fastened to the pump hardware.

To reduce the risk of static electrical sparking, this pump must be grounded. Check the local electrical code for detailed grounding instruction and the type of equipment required, or in the absence of local codes, an industry or nationally recognized code having jurisdiction over specific installations, and/or CAN/CGA B149, installation codes.

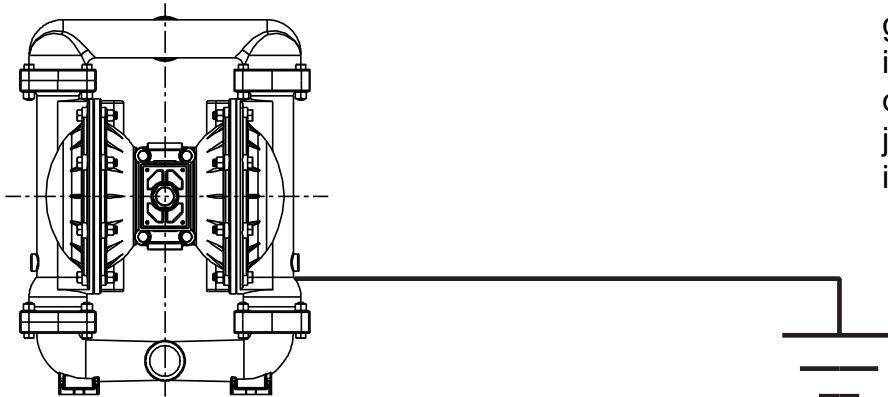

	<b>! WARNING</b>
	<i>Take action to prevent static sparking. Fire or explosion can result, especially when handling flammable liquids. The pump, piping, valves, containers or other miscellaneous equipment must be grounded.</i>

Declaration of Conformity



**WARREN  
RUPP®**

**IDEX**  
FLUID & METERING

## Declaration of Conformity

Warren Rupp, Inc., 800 North Main Street, Mansfield, Ohio, certifies that Air-Operated Double Diaphragm Pumps Series: HDB, HDF, M Non-Metallic, S Non-Metallic, M Metallic, S Metallic, Containment Duty, Gas, UL, High Pressure, W, Submersible and Tranquilizers comply with the European Community Directive 98/37/EC, Safety of Machinery. This product has used EN 809, Pumps and Pump Units for Liquids - Common Safety Requirements harmonized standard to verify conformance.

*David Roseberry*

Signature of authorized person

October 20, 2005

Date of issue

David Roseberry

Printed name of authorized person

Engineering Manager

Title

CE



Declaration of Conformity

**WARREN  
RUPP®**

**IBEX**  
FLUID & METERING

# Declaration of Conformity ATEX 100a

In accordance with Directive 94/9/EC, Annex VIII Equipment intended for use in potentially explosive environments. Technical File No. AX1 is stored at KEMA, Notified Body 0344, under document number 203040000.

**Manufacturer:**

Warren Rupp, Inc.  
800 North Main Street  
P.O. Box 1568  
Mansfield, OH 44902 USA

**Applicable Standard:**

94/9/EC  
EN13463-1  
For potentially explosive environments  
Group I, Category M2  
Group II, Category 2 GD



**Models:**

**Air-Operated Double Diaphragm Metallic Pumps Series:** EH, ET, G, HDB, HDF, M, MHP, MS, MP, SH, S, SA, SB, ST, T and U under SANDPIPER® and MARATHON® Brands

**Metal Surge Suppressors Series:** T and MSS under Tranquilizer® and MARATHON® Brands

**Air-Operated Double Diaphragm Nonmetallic Conductive Acetal Pump Models:** PB¼ and S05

**Air-Operated Double Diaphragm Nonmetallic Conductive Polypropylene Pump Models:** S05, S1F, S15, S20

**SANDPIPER®**  
A WARREN RUPP PUMP BRAND

**MARATHON®**  
A WARREN RUPP PUMP BRAND

**DATE/APPROVAL/TITLE:**

8 May 2003

Rev F 12 January 2007

*David Roseberry*  
David Roseberry, Engineering Manager