



Always the Right Solution™

Section:
MOYNO® 500 PUMPS
Page:1 of 4
Date: March 1, 1998

SERVICE MANUAL

MOYNO® 500 PUMPS

200 SERIES MOTORIZED

20352, 20452, 20551, 20552, 22051 AND 22052 MODELS

DESIGN FEATURES

- Housing: AISI 316 stainless steel, or phenolic
- Pump Rotor: Phenolic, AISI 316 stainless steel
- Pump Stator: NBR (Nitrile)
- Seal: Mechanical (carbon/ceramic)
- Motor Shaft: AISI 316 stainless steel
- Motor: 115V AC, 1/8 HP, 50/60 Hertz, 1725 rpm, ball bearing, Class B insulation, capacitor start (other motor options available; consult Sales Representative)

Note: Alternate elastomers available. Refer to Repair/Conversion kit numbers, page 3.



INSTALLATION

Mounting Position. Pump may be mounted in any position. When mounting vertically, it is necessary to keep bearings above seals to prevent possible seal leakage into bearings.

Pre-Wetting. Prior to connecting pump, wet pump elements and mechanical seal by adding fluid to be pumped into suction and discharge ports. Turn pump over several times in a clockwise direction using screwdriver slot in end of motor shaft.

Piping. Piping to pump should be self-supporting to avoid excessive strain on pump housings; 3/8" NPT pipe for suction, and 1/4" NPT pipe for discharge on all metal housing models. 5/8" ID hose with hose clamp for suction and discharge ports of plastic housing models. Use pipe "dope" or tape to facilitate disassembly and to provide seal on pipe connections.

Electrical. Follow the wiring diagram on the motor nameplate or inside the terminal box for the proper connections. The wiring should be direct and conform to local electrical codes. Check power connections for proper voltage. Voltage variations must not exceed ± 10% of nameplate voltage. Motor is provided with internal automatic overload protection.

To prevent damage to pump, pump rotation must be clockwise when facing pump from motor end.

OPERATION

Self-Priming. With wetted pumping elements, the pump is capable of 25 feet of suction lift with pipe size equal to port size. Be sure suction lines are air tight or pump will not self-prime.

DO NOT RUN DRY. Unit depends on liquid pumped for lubrication. For proper lubrication, flow rate should be at least 10% of rated capacity.

Pressure and Temperature Limits.

Maximum discharge pressure is 40 psig. Unit is suitable for service at temperatures shown in Table 1.

Storage. Always drain pump for extended storage periods by removing suction housing bolts and loosening suction housing.

Table 1. Temperature Limits

Elastomer	Temperature Limits
*NBR	10°-160°F
*EPDM	10°-210°F
*FPM	10°-240°F

*NBR = Nitrile

EPDM = Ethylene-Propylene-Diene Terpolymer

FPM = Fluoroelastomer

TROUBLE SHOOTING

WARNING: Before making adjustments, disconnect power source and thoroughly bleed pressure from system. Failure to do so could result in electric shock or serious bodily harm.

Failure To Pump.

1. Motor won't start: Check power supply. Voltage must be $\pm 10\%$ nameplate rating when motor is in locked rotor condition. Do not use less than #14 wire size.
2. Motor runs and thermally kicks out: Increase ventilation to motor. Check for defective relay, or defective capacitor. Check for excessive pressure.
3. Stator torn; possibly excessive pressure: Replace stator, check pressure at discharge port.
4. Excessive suction lift or vacuum.

Pump Overloads.

1. Excessive discharge pressure: Check discharge pressure for 40 psig maximum or obstruction in discharge line.
2. Fluid viscosity too high: Limit fluid viscosity to 100 CP or 500 SSU.

Noisy Operation.

1. Starved suction: Check fluid level, size of piping, and obstructions in pipe.
2. Bearings worn: Replace parts
3. Insufficient mounting: Mount securely. Reduce vibration induced noise by using a short section of hose on discharge piping.

Seal Leakage.

1. Leakage at startup: If leakage is slight, allow pump to run several hours to let faces run in.
2. Persistent seal leakage: Faces may be cracked from freezing or thermal shock. Replace seal.

Pump Will Not Prime.

1. Air leak on suction side: Check pipe connections.

PUMP DISASSEMBLY

WARNING: Before disassembling pump, disconnect power source and thoroughly bleed pressure from system. Failure to do so could result in electric shock or serious bodily harm.

1. Remove suction and discharge piping.
2. Remove screws (112) holding suction housing (2) and pump body (1) to motor (70). Remove suction housing (2) and stator (21).
3. Remove rotor (22) from shaft by turning in a counterclockwise direction. Keep shaft from turning by inserting screwdriver in slotted end of motor shaft.
4. Remove slinger ring (110), pump body (1), and mechanical seal (69).
5. If any parts of the mechanical seal (69) are worn or broken, the complete seal assembly should be replaced. Seal components are matched parts and are not interchangeable.

PUMP ASSEMBLY

1. Slip slinger ring (110) over motor shaft. Place pump body (1) in position on motor (70).
2. Install mechanical seal (69) using the following procedure:
 - a. Clean and oil sealing faces using a clean light oil (not grease).

Caution: Do not use oil on EPDM parts. Substitute glycerin or soap and water.

- b. Oil the outer surface of the seal seat, and push the assembly into the seal bore in the pump body (1), seating it firmly and squarely.
 - c. After cleaning and oiling the shaft, slide the seal body along the shaft until it meets the seal seat.
 - d. Install seal spring and spring retainer on shaft.
3. Screw rotor (22) on shaft in a clockwise direction. Keep shaft from turning by inserting screwdriver in slotted end of motor shaft.
 4. Secure stator (21), suction housing (2), and pump body (1) to motor (70) using screws (112).
 5. Connect hose or piping and proceed as in installation instructions.

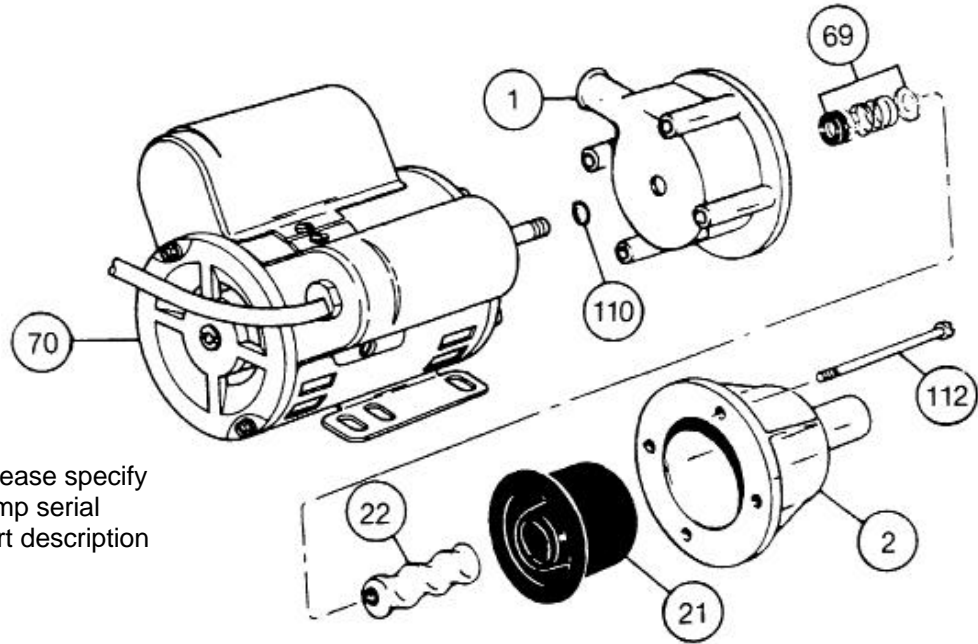

When ordering parts, please specify pump model number, pump serial number, part number, part description and quantity.

PARTS LIST

Item No.	Description	Pump Model Numbers					
		20352	20452	20551	20552	22051	22052
1	Pump Body	316 SS 330-3330-000		Phenolic 330-2953-000	316 SS 330-3330-000	Phenolic 330-2953-000	316 SS 330-3330-000
2	Suction Housing	316 SS 330-3327-000		Phenolic 330-2954-000	316 SS 330-3327-000	Phenolic 330-2954-000	316 SS 330-3327-000
*21	Stator	NBR 330-7555-120	NBR 330-7556-120	NBR 330-6381-120		NBR 330-6382-120	
*22	Rotor	316 SS 320-6975-000	316 SS 320-7923-000	Phenolic 320-6485-000	316 SS 320-6484-000	Phenolic 320-6488-000	316 SS 320-6487-000
*69	Mechanical Seal	NBR 320-6480-000					
70	Motor	330-4596-000					
110	Slinger Ring	320-2833-008					
112	Screws (4 req.)	619-0050-301					

*Recommended spare parts.

REPAIR/CONVERSION KIT NUMBERS (Not available as kit for 20352, 20452 Models)

Item No.	Description	205 Models			220 Models		
		NBR	EPDM	FPM	NBR	EPDM	FPM
-	Kit No.	311-9116-000	311-9118-000	311-9120-000	311-9117-000	311-9119-000	311-9121-000
21	• Stator	330-6381-120	330-6381-320	330-6381-520	330-6382-120	330-6382-320	330-6382-520
69	• Seal	320-6480-000	320-6481-000	320-6482-000	320-6480-000	320-6481-000	320-6482-000

NBR = Nitrile
 EPDM = Ethylene-Propylene-Diene Terpolymer
 FPM = Fluoroelastomer

